

SPX Drives



Contents

Description**Page**

SPX Drives	
Features and Benefits	V6-T2-258
Standards and Certifications	V6-T2-258
Catalog Number Selection	V6-T2-259
Product Selection	V6-T2-260
Accessories	V6-T2-265
Options	V6-T2-266
Replacement Parts	V6-T2-273
Technical Data and Specifications	V6-T2-280
Dimensions	V6-T2-281

Product Description

The SPX Series Adjustable Frequency Drives from Eaton's Electrical Sector are specifically designed for high performance applications. Equipped with high processing power, the SPX can use information from an encoder or a resolver in order to provide very precise motor control. Sensorless vector and simple frequency control are also supported. Typical applications requiring high performance are: master-slave drives, positioning applications, winder tension control and synchronization.

The core of the SPX is a fast microprocessor, providing high dynamic performance for applications where good motor handling and reliability are required. It can be used both in open loop applications as well as in applications requiring encoder feedback.

The SPX supports fast drive-to-drive communication. It also offers an integrated data logger functionality for analysis of dynamic events without the need of additional hardware. Simultaneous fast monitoring of several drives can be done by using the 9000Xdrive tool and CAN communication. In applications where reliability and quality are essential for high-performance, the SPX is the logical choice.

The Eaton family of drives includes DA1, DC1, H-Max, M-Max, SVX and SPX. 9000X Series drive ratings are rated for either high overload (I_H) or low overload (I_L). I_L indicates 110% overload capacity for 1 minute out of 10 minutes. I_H indicates 150% overload capacity for 1 minute out of 10 minutes.

Features and Benefits

- Speed error <0.01 %, depending on the encoder
- Incremental or absolute encoder support
- Encoder voltages of 5 V (RS-422), 15 V or 24 V, depending on the option card
- Full torque control at all speeds, including zero
- Torque accuracy <2%; <5% down to zero speed
- Starting torque >200%, depending on motor and drive sizing
- Integrated datalogger for system analysis
- Fast multiple drive monitoring with PC
- Full capability for master/slave configurations
- High-speed bus (12 Mbit/s) for fast inter-drive communication
- High-speed applications (up to 7200 Hz) possible with special software
- Robust design—proven 500,000 hours MTBF
- Integrated 3% line reactors standard on drives from FR4 through FR9
- Line reactor is included but is separated from chassis
- EMI/RFI Filters H standard up to 200 hp I_H 480 V, 100 hp I_H 230 V
- Simplified operating menu allows for typical programming changes, while programming mode provides control of everything
- Quick Start Wizard built into the programming of the drive ensures a smooth start-up
- Keypad can display up to three monitored parameters simultaneously
- LOCAL/REMOTE operation from keypad
- Copy/paste function allows transfer of parameter settings from one drive to the next
- Standard NEMA Type 12/IP54 keypad on all drives
- Hand-held auxiliary 240 power supply allows programming/monitoring of control module without applying full power to the drive
- The SPX can be flexibly adapted to a variety of needs using our pre-installed “Seven in One” precision application programs consisting of:
 - Basic
 - Standard
 - Local/remote
 - Multi-step speed control
 - PID control
 - Multi-purpose control
 - Pump and fan control with auto change
- Additional I/O and communication cards provide plug and play functionality
- I/O connections with simple quick connection terminals
- Control logic can be powered from an external auxiliary control panel, internal drive functions and fieldbus if necessary
- Brake chopper standard from: 1–30 hp/380–500 V 3/4–15 hp/208–230 V
- NEMA Type 1/IP21 enclosures available Frame Sizes FR4–FR11, NEMA Type 12/IP54 enclosures available Frame Sizes FR4–FR10 (FR10 and FR11 freestanding drives)
- Open chassis FR10 and greater
- Standard option board configuration includes an A9 I/O board and an A2 relay output board installed in slots A and B

Standards and Certifications

Product

- IEC 61800-2

Safety

- UL 508C

EMC (at default settings)

- Immunity: Fulfills all EMC immunity requirements; Emissions: EN 61800-3, LEVEL H

- UL Listed
- CE



Catalog Number Selection

SPX Adjustable Frequency Drives

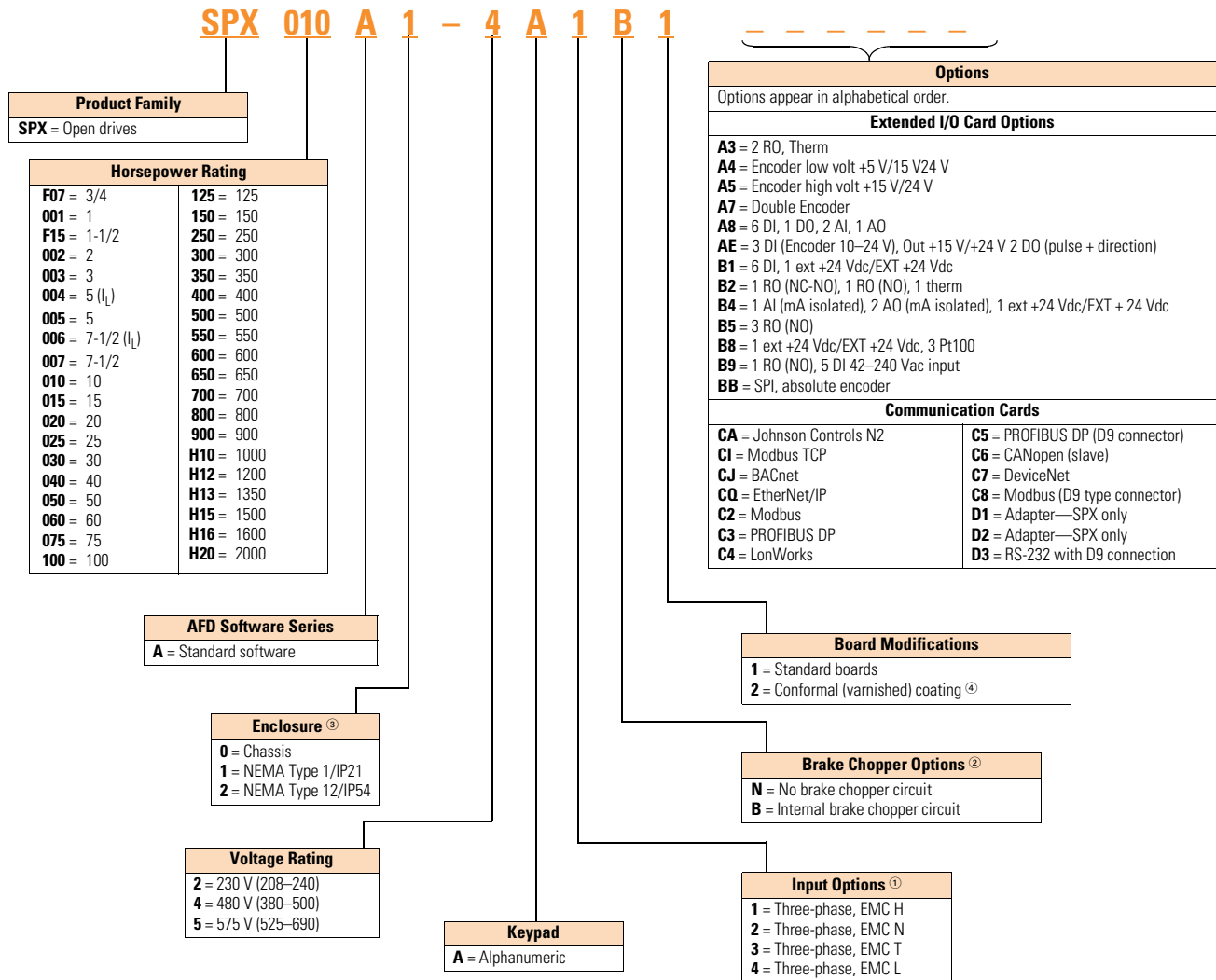

Notes

- ① All 230 V drives and 480 V drives up to 200 hp (I_H) are only available with input option **1** (EMC level H), 480 V drives 250 hp (I_H) or larger are available with input option **2** (EMC level N), 575 V drives 200 hp (I_H) or larger are available with input option **2**. 575 V drives up to 150 hp (I_H) are available with input option **4** (EMC level L). 480 V and 690 V freestanding drives are available with input option **4** (EMC level L).
- ② 480 V drives up to 30 hp (I_H) are only available with brake chopper option **B**. 480 V drives 40 hp (I_H) or larger come standard with brake chopper option **N**. 230 V drives up to 15 hp (I_H) are only available with brake chopper option **B**. 230 V drives 20 hp and larger come standard with brake chopper option **N**. All 575 V drives come standard without brake chopper option (**N**). **N = No** brake chopper.
- ③ 480 V drives 250–350 hp (I_H) and 690 V drives 200–300 hp (I_H) are available with enclosure style **0** (chassis). 480 V and 690 V FR10 freestanding drives are available with **1** (NEMA Type 1/IP21) or **2** (NEMA Type 12/IP54). FR11 freestanding drives are only available with enclosure style **1** (NEMA Type 1/IP21).
- ④ Factory promise delivery. Consult sales office for availability.
- ⑤ For High-Resistance Ground systems, any SVX/SPX drive can be used if the HRG system has ground supervision. If no ground supervision feature is available, use EMC class N or T.

Product Selection

2

230 V Drives

SPX Open Drives



208–240 V, NEMA Type 1/IP21 Drives

Frame Size	hp (I _H)	Current (I _H)	hp (I _L)	Current (I _L)	Catalog Number
FR4	3/4	3.7	1	4.8	SPXF07A1-2A1B1
	1	4.8	1-1/2	6.6	SPX001A1-2A1B1
	1-1/2	6.6	2	7.8	SPXF15A1-2A1B1
	2	7.8	3	11	SPX002A1-2A1B1
	3	11	—	12.5	SPX003A1-2A1B1
FR5	—	12.5	5	17.5	SPX004A1-2A1B1
	5	17.5	7-1/2	25	SPX005A1-2A1B1
	7-1/2	25	10	31	SPX007A1-2A1B1
FR6	10	31	15	48	SPX010A1-2A1B1
	15	48	20	61	SPX015A1-2A1B1
FR7	20	61	25	75	SPX020A1-2A1N1
	25	75	30	88	SPX025A1-2A1N1
	30	88	40	114	SPX030A1-2A1N1
FR8	40	114	50	140	SPX040A1-2A1N1
	50	140	60	170	SPX050A1-2A1N1
	60	170	75	205	SPX060A1-2A1N1
FR9	75	205	100	261	SPX075A1-2A1N1
	100	261	—	—	SPX100A1-2A1N1

208–240 V, NEMA Type 12/IP54 Drives

Frame Size	hp (I _H)	Current (I _H)	hp (I _L)	Current (I _L)	Catalog Number
FR4	3/4	3.7	1	4.8	SPXF07A2-2A1B1
	1	4.8	1-1/2	6.6	SPX001A2-2A1B1
	1-1/2	6.6	2	7.8	SPXF15A2-2A1B1
	2	7.8	3	11	SPX002A2-2A1B1
	3	11	—	12.5	SPX003A2-2A1B1
FR5	—	12.5	5	17.5	SPX004A2-2A1B1
	5	17.5	7-1/2	25	SPX005A2-2A1B1
	7-1/2	25	10	31	SPX007A2-2A1B1
FR6	10	31	15	48	SPX010A2-2A1B1
	15	48	20	61	SPX015A2-2A1B1
FR7	20	61	25	75	SPX020A2-2A1N1
	25	75	30	88	SPX025A2-2A1N1
	30	88	40	114	SPX030A2-2A1N1
FR8	40	114	50	140	SPX040A2-2A1N1
	50	140	60	170	SPX050A2-2A1N1
	60	170	75	205	SPX060A2-2A1N1
FR9	75	205	100	261	SPX075A2-2A1N1
	100	261	—	—	SPX100A2-2A1N1

480 V Drives

SPX Open Drives



380–500 V, NEMA Type 1/IP21 Drives

Frame Size	hp (I _H)	Current (I _H)	hp (I _L)	Current (I _L)	Catalog Number
FR4	1	2.2	1-1/2	3.3	SPX001A1-4A1B1
	1-1/2	3.3	2	4.3	SPXF15A1-4A1B1
	2	4.3	3	5.6	SPX002A1-4A1B1
	3	5.6	5	7.6	SPX003A1-4A1B1
	5	7.6	—	9	SPX005A1-4A1B1
	—	9	7-1/2	12	SPX006A1-4A1B1
FR5	7-1/2	12	10	16	SPX007A1-4A1B1
	10	16	15	23	SPX010A1-4A1B1
	15	23	20	31	SPX015A1-4A1B1
FR6	20	31	25	38	SPX020A1-4A1B1
	25	38	30	46	SPX025A1-4A1B1
	30	46	40	61	SPX030A1-4A1B1
FR7	40	61	50	72	SPX040A1-4A1N1
	50	72	60	87	SPX050A1-4A1N1
	60	87	75	105	SPX060A1-4A1N1
FR8	75	105	100	140	SPX075A1-4A1N1
	100	140	125	170	SPX100A1-4A1N1
	125	170	150	205	SPX125A1-4A1N1
FR9	150	205	200	261	SPX150A1-4A1N1
	200	245	250	300	SPX200A1-4A1N1

380–500 V, NEMA Type 1/IP21 Freestanding Drives

Frame Size	hp (I _H)	Current (I _H)	hp (I _L)	Current (I _L)	Catalog Number
FR10	250	330	300	385	SPX250A1-4A4N1
	300	385	350	460	SPX300A1-4A4N1
	350	460	400	520	SPX350A1-4A4N1
FR11	400	520	500	590	SPX400A1-4A4N1
	500	590	550	650	SPX500A1-4A4N1
	550	650	600	730	SPX550A1-4A4N1

Note

Integrated fuses as standard. Limited option selection available; 115 V transformer (KB), light kit (L1), HOA (K4), speed potentiometer w/HOA (K2), Disconnect switch (P2). See Freestanding Option selection on **Page V6-T2-272**.

SPX Open Drives

2



380–500 V, NEMA Type 12/IP54 Drives

Frame Size	hp (I _H)	Current (I _H)	hp (I _L)	Current (I _L)	Catalog Number
FR4	1	2.2	1-1/2	3.3	SPX001A2-4A1B1
	1-1/2	3.3	2	4.3	SPXF15A2-4A1B1
	2	4.3	3	5.6	SPX002A2-4A1B1
	3	5.6	5	7.6	SPX003A2-4A1B1
	5	7.6	—	9	SPX005A2-4A1B1
	—	9	7-1/2	12	SPX006A2-4A1B1
FR5	7-1/2	12	10	16	SPX007A2-4A1B1
	10	16	15	23	SPX010A2-4A1B1
	15	23	20	31	SPX015A2-4A1B1
FR6	20	31	25	38	SPX020A2-4A1B1
	25	38	30	46	SPX025A2-4A1B1
	30	46	40	61	SPX030A2-4A1B1
FR7	40	61	50	72	SPX040A2-4A1N1
	50	72	60	87	SPX050A2-4A1N1
	60	87	75	105	SPX060A2-4A1N1
FR8	75	105	100	140	SPX075A2-4A2N1
	100	140	125	170	SPX100A2-4A1N1
	125	170	150	205	SPX125A2-4A1N1
FR9	150	205	200	261	SPX150A2-4A1N1
	200	245	250	300	SPX200A2-4A1N1

380–500 V, NEMA Type 12/IP54 Freestanding Drives

Frame Size	hp (I _H)	Current (I _H)	hp (I _L)	Current (I _L)	Catalog Number
FR10	250	330	300	385	SPX250A2-4A4N1
	300	385	350	460	SPX300A2-4A4N1
	350	460	400	520	SPX350A2-4A4N1

380–500 V, Open Chassis Drives

Frame Size	hp (I _H)	Current (I _H)	hp (I _L)	Current (I _L)	Catalog Number
FR10	250	330	300	385	SPX250A0-4A2N1
	300	385	—	460	SPX300A0-4A2N1
	350	460	400	520	SPX350A0-4A2N1
FR11	400	520	500	590	SPX400A0-4A2N1
	500	590	—	650	SPX500A0-4A2N1
	—	650	600	730	SPX550A0-4A2N1
FR12	600	730	—	820	SPX600A0-4A2N1
	—	820	700	920	SPX650A0-4A2N1
	700	920	800	1030	SPX700A0-4A2N1
FR13	800	1030	900	1150	SPX800A0-4A2N1
	900	1150	1000	1300	SPX900A0-4A2N1
	1000	1300	1200	1450	SPXH10A0-4A2N1
FR14	1200	1600	1500	1770	SPXH12A0-4A2N1
	1600	1940	1800	2150	SPXH16A0-4A2N1

Notes

Integrated fuses as standard. Limited option selection available; 115 V transformer (KB), light kit (L1), HOA (K4), speed potentiometer w/HOA (K2), disconnect switch (P2). See Freestanding Option selection on [Page V6-T2-272](#).

① FR10–FR14 includes 3% line reactor, but it is not integral to chassis.

575 V Drives

SPX Open Drives



525–690 V, NEMA Type 1/IP21 Drives

Frame Size	hp (I _H)	Current (I _H)	hp (I _L)	Current (I _L)	Catalog Number
FR6	2	3.3	3	4.5	SPX002A1-5A4N1
	3	4.5	—	5.5	SPX003A1-5A4N1
	—	5.5	5	7.5	SPX004A1-5A4N1
	5	7.5	7-1/2	10	SPX005A1-5A4N1
	7-1/2	10	10	13.5	SPX007A1-5A4N1
	10	13.5	15	18	SPX010A1-5A4N1
	15	18	20	22	SPX015A1-5A4N1
	20	22	25	27	SPX020A1-5A4N1
	25	27	30	34	SPX025A1-5A4N1
FR7	30	34	40	41	SPX030A1-5A4N1
	40	41	50	52	SPX040A1-5A4N1
FR8	50	52	60	62	SPX050A1-5A4N1
	60	62	75	80	SPX060A1-5A4N1
	75	80	100	100	SPX075A1-5A4N1
FR9	100	100	125	125	SPX100A1-5A4N1
	125	125	150	144	SPX125A1-5A4N1
	150	144	—	170	SPX150A1-5A4N1
	—	170	200	208	SPX175A1-5A4N1

525–690 V, NEMA Type 1/IP21 Freestanding Drives

Frame Size	hp (I _H)	Current (I _H)	hp (I _L)	Current (I _L)	Catalog Number
FR10	200	208	250	261	SPX200A1-5A4N1
	250	261	300	325	SPX250A1-5A4N1
	300	325	400	385	SPX300A1-5A4N1
FR11	400	385	450	460	SPX400A1-5A4N1
	450	460	500	502	SPX450A1-5A4N1
	500	502	550	590	SPX500A1-5A4N1

Note

Integrated fuses as standard. Limited option selection available; 115 V transformer (KB), light kit (L1), HOA (K4), speed potentiometer w/HOA (K2), disconnect switch (P2). See Freestanding Option selection on **Page V6-T2-272**.

2.10

Adjustable Frequency Drives

SPX Drives

SPX Open Drives



2

525–690 V, NEMA Type 12/IP54 Drives

Frame Size	hp (I _H)	Current (I _H)	hp (I _L)	Current (I _L)	Catalog Number
FR6	2	3.3	3	4.5	SPX002A2-5A4N1
	3	4.5	—	5.5	SPX003A2-5A4N1
	—	5.5	5	7.5	SPX004A2-5A4N1
	5	7.5	7-1/2	10	SPX005A2-5A4N1
	7-1/2	10	10	13.5	SPX007A2-5A4N1
	10	13.5	15	18	SPX010A2-5A4N1
	15	18	20	22	SPX015A2-5A4N1
	20	22	25	27	SPX020A2-5A4N1
FR7	25	27	30	34	SPX025A2-5A4N1
	30	34	40	41	SPX030A2-5A4N1
	40	41	50	52	SPX040A2-5A4N1
FR8	50	52	60	62	SPX050A2-5A4N1
	60	62	75	80	SPX060A2-5A4N1
	75	80	100	100	SPX075A2-5A4N1
FR9	100	100	125	125	SPX100A2-5A4N1
	125	125	150	144	SPX125A2-5A4N1
	150	144	—	170	SPX150A2-5A4N1
	—	170	200	208	SPX175A2-5A4N1

525–690 V, NEMA Type 12/IP54 Freestanding Drives

Frame Size	hp (I _H)	Current (I _H)	hp (I _L)	Current (I _L)	Catalog Number
FR10	200	208	250	261	SPX200A2-5A4N1
	250	261	300	325	SPX250A2-5A4N1
	300	325	400	385	SPX300A2-5A4N1

525–690 V, Open Chassis Drives

Frame Size	hp (I _H)	Current (I _H)	hp (I _L)	Current (I _L)	Catalog Number
FR10	200	208	250	261	SPX200A0-5A2N1
	250	261	300	325	SPX250A0-5A2N1
	300	325	400	385	SPX300A0-5A2N1
FR11	400	385	450	460	SPX400A0-5A2N1
	450	460	500	502	SPX450A0-5A2N1
	500	502	—	590	SPX500A0-5A2N1
FR12	—	590	600	650	SPX550A0-5A2N1
	600	650	700	750	SPX600A0-5A2N1
	700	750	800	820	SPX700A0-5A2N1
FR13	800	820	900	920	SPX800A0-5A2N1
	900	920	1000	1030	SPX900A0-5A2N1
	1000	1030	1250	1180	SPXH10A0-5A2N1
FR14	1350	1300	1500	1500	SPXH13A0-5A2N1
	1500	1500	2000	1900	SPXH15A0-5A2N1
	2000	1900	2300	2250	SPXH20A0-5A2N1

Notes

Integrated fuses as standard. Limited option selection available; 115 V transformer (KB), light kit (L1), HOA (K4), speed potentiometer w/HOA (K2), disconnect switch (P2). See Freestanding Option selection on [Page V6-T2-272](#).

Ⓞ FR10–FR14 includes 3% line reactor, but it is not integral to chassis.

Accessories

Demo Drive and Power Supply

Demo Drive and Power Supply

Description	Catalog Number
9000X demo drive	9000XDEMO

9000X Series—SVX/SPX Conversion and Flange Kits

The Type 12/IP54 option kit is used to convert a Type 1/IP21 to a Type 12/IP54 drive. The kit includes:

NEMA Type 12 / IP54 Conversion Kits

Frame Size	Catalog Number
Frame 4 Type 12/IP54 kit	OPTN12FR4
Frame 5 Type 12/IP54 kit	OPTN12FR5
Frame 6 Type 12/IP54 kit	OPTN12FR6

Flange Kits

The flange kit is used when the power section heat sink is mounted through the back panel of an enclosure. The kit includes hardware and supporting steel plates.

NEMA Type 12 / IP54 Conversion Kits

Kit

Frame Size	Catalog Number
Frame 4 flange kit Type 12/IP54	OPTTHR4
Frame 5 flange kit Type 12/IP54	OPTTHR5
Frame 6 flange kit Type 12/IP54	OPTTHR6
Frame 7 flange kit Type 12/IP54	OPTTHR7
Frame 8 flange kit Type 12/IP54	OPTTHR8
Frame 9 flange kit Type 12/IP54	OPTTHR9

2.10

Adjustable Frequency Drives

SPX Drives

Options

9000X Series Option Board Kits

2

The 9000X Series drives can accommodate a wide selection of expander and adapter option boards to customize the drive for your application needs. The drive's control unit is designed to accept a total of five option boards.

The 9000X Series factory installed standard board configuration includes an A9 I/O board and an A2 relay output board, which are installed in slots A and B.

Option Boards

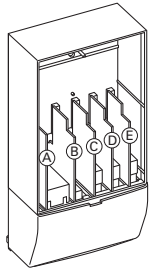

Option Board Kits

Option Kit Description ^①	Allowed Slot Locations ^②	Field Installed Catalog Number	Factory Installed Option Designator	SVX Ready Programs						
				Basic	Local/Remote	Standard	MSS	PID	Multi-P.	PFC
Standard I/O Cards										
6 DI, 1 DO, 2 AI, 1 AO, 1 +10 Vdc ref, 2 ext +24 Vdc/EXT +24 Vdc	A	OPTA9	—	■	■	■	■	■	■	■
2 RO (NC-NO)	B	OPTA2	—	■	■	■	■	■	■	■
Extended I/O Cards										
2 RO, therm	B	OPTA3	A3	—	■	■	■	■	■	■
Encoder low volt +5 V/15 V/24 V	C	OPTA4	A4	—	■	■	■	■	■	■
Encoder high volt +15 V/24 V	C	OPTA5	A5	—	■	■	■	■	■	■
Double encoder—SPX only	C	OPTA7	A7	■	■	■	■	■	■	■
6 DI, 1 DO, 2 AI, 1 AO	A	OPTA8	A8	—	■	■	■	■	■	■
6 DI, 1 DO, 2 AI, 1 AO, 1 +10 Vdc ref, 2 ext +24 Vdc/EXT +24 Vdc	A	OPTA1	—	■	■	■	■	■	■	■
3 DI (encoder 10–24 V), out +15 V/+24 V, 2 DO (pulse+direction)—SPX only	C	OPTAE	AE	■	■	■	■	■	■	■
6 DI, 1 DO, 2 AI, 1 AO, 1 +10 Vdc ref, 2 ext +24 Vdc/EXT +24 Vdc	A	OPTAFA1	—	■	■	■	■	■	■	■
6 DI, 1 ext +24 Vdc/EXT +24 Vdc	B, C, D , E	OPTB1	B1	—	—	—	—	—	■	■
1 RO (NC-NO), 1 RO (NO), 1 therm	B, C, D , E	OPTB2	B2	—	—	—	—	—	■	■
1 AI (mA isolated), 2 AO (mA isolated), 1 ext +24 Vdc/EXT +24 Vdc	B, C, D , E	OPTB4	B4	—	■	■	■	■	■	■
3 RO (NO)	B, C, D , E	OPTB5	B5	—	—	—	—	—	■	■
1 ext +24 Vdc/EXT +24 Vdc, 3 Pt100	B, C, D , E	OPTB8	B8	—	—	—	—	—	—	—
1 RO (NO), 5 DI 42–240 Vac input	B, C, D , E	OPTB9	B9	—	—	—	—	—	■	■
SPI, absolute encoder	C	OPTBB	BB	—	—	—	—	—	—	—
Communication Cards										
Modbus RTU	D, E	OPTC2	C2	■	■	■	■	■	■	■
Modbus RTU (D9 connector)	D, E	OPTC8	C8	■	■	■	■	■	■	■
PROFIBUS DP	D, E	OPTC3	C3	■	■	■	■	■	■	■
PROFIBUS DP (D9 connector)	D, E	OPTC5	C5	■	■	■	■	■	■	■
Johnson Controls N2	D, E	OPTC2	CA	—	—	—	—	—	—	—
BACnet MSTP	D, E	OPTCJ	CJ	■	■	■	■	■	■	■
LonWorks	D, E	OPTC4	C4	■	■	■	■	■	■	■
CANopen (slave)	D, E	OPTC6	C6	■	■	■	■	■	■	■
DeviceNet	D, E	OPTC7	C7	■	■	■	■	■	■	■
Modbus TCP	D, E	OPTCI	CI	■	■	■	■	■	■	■
EtherNet/IP	D, E	OPTCQ	CQ	■	■	■	■	■	■	■
PROFINET, Modbus TCP, EtherNet/IP (dual-port) ^④	D, E	OPTC9	E9	■	■	■	■	■	■	■
EtherCAT (dual-port) ^④	D, E	OPTCQ	EC	■	■	■	■	■	■	■
SPX adapter	D, E	OPTD1	D1	■	■	■	■	■	■	■
SPX adapter	D, E	OPTD2	D2	■	■	■	■	■	■	■
RS-232 adapter	D, E	OPTD3	D3	■	■	■	■	■	■	■

Notes

- ① AI = Analog Input; AO = Analog Output, DI = Digital Input, DO = Digital Output, RO = Relay Output
- ② Option card must be installed in one of the slots listed for that card. Slot indicated in bold is the preferred location.
- ③ OPTC2 is a multi-protocol option card.

Modbus RTU Network Communications

The Modbus Network Card OPTC2 is used for connecting the SVX Drive as a slave on a Modbus network. The interface is connected by a 9-pin DSUB connector (female) and the baud rate ranges from 300 to 19,200 baud. Other communication parameters include an address range from 1 to 247; a parity of None, Odd or Even; and the stop bit is 1.

PROFIBUS Network Communications

The PROFIBUS Network Card OPTC3 is used for connecting the SVX Drive as a slave on a PROFIBUS-DP network. The interface is connected by a 9-pin DSUB connector (female). The baud rates range from 9.6 Kbaud to 12 Mbaud, and the addresses range from 1 to 127.

LonWorks Network Communications

The LonWorks Network Card OPTC4 is used for connecting the SVX Drive on a LonWorks network. This interface uses Standard Network Variable Types (SNVT) as data types. The channel connection is achieved using a FTT-10 A Free Topology transceiver via a single twisted transfer cable. The communication speed with LonWorks is 78 kBits/s.

CANopen (Slave) Communications

The CANopen (Slave) Network Card OPTC6 is used for connecting the SVX Drive to a host system. According to ISO11898 standard cables to be chosen for CANbus should have a nominal impedance of 120 ohms, and specific line delay of nominal 5 nS/m. 120 ohms line termination resistors required for installation.

DeviceNet Network Communications

The DeviceNet Network Card OPTC7 is used for connecting the SVX Drive on a DeviceNet Network. It includes a 5.08 mm pluggable connector. Transfer method is via CAN using a two-wire twisted shielded cable with two-wire bus power cable and drain. The baud rates used for communication include 125 Kbaud, 250 Kbaud and 500 Kbaud.

Johnson Controls Metasys N2 Network Communications

The OPTC2 fieldbus board provides communication between the SVX Drive and a Johnson Controls Metasys™ N2 network. With this connection, the drive can be controlled, monitored and programmed from the Metasys system. The N2 fieldbus is available as a factory installed option and as a field installable kit.

Modbus/TCP Network Communications

The Modbus/TCP Network Card OPTCI is used for connecting the SVX Drive to Ethernet networks utilizing Modbus protocol. It includes an RJ-45 pluggable connector. This interface provides a selection of standard and custom register values to communicate drive parameters. The board supports 10 Mbps and 100 Mbps communication speeds. The IP address of the board is configurable over Ethernet using a supplied software tool.

BACnet Network Communications

The BACnet Network Card OPTCJ is used for connecting the SVX Drive to BACnet networks. It includes a 5.08 mm pluggable connector. Data transfer is Master-Slave/Token Passing (MS/TP) RS-485. This interface uses a collection of 30 Binary Value Objects (BVOs) and 35 Analog Value Objects (AVOs) to communicate drive parameters. The card supports 9.6, 19.2 and 38.4 Kbaud communication speeds and supports network addresses 1–127.

EtherNet/IP Network Communications

The OPTCQ is used for connecting the SVX Drive to Ethernet/Industrial Protocol networks. It includes an RJ-45 pluggable connector. The interface uses CIP objects to communicate drive parameters (CIP is “Common Industrial Protocol”, the same protocol used by DeviceNet). The board supports 10 Mbps and 100 Mbps communication speeds. The IP address of the board is configurable by Static, BOOTP and DHCP methods.

2.10

Adjustable Frequency Drives

SPX Drives

Control Panel Options

Factory Options

2

Description	Factory Installed Option Code	Field Installed NEMA Type 1/IP21 Catalog Number
Local/Remote Keypad SVX Control Panel —This option is standard on all drives and consists of an RS-232 connection, backlit alphanumeric LCD display with nine indicators for the RUN status and two indicators for the control source. The nine pushbuttons on the panel are used for panel programming and monitoring of all SVX parameters. The panel is detachable and isolated from the input line potential. Include LOC/REM key to choose control location.	A	KEYPAD-LOC/REM
Keypad Remote Mounting Kit —This option is used to remote mount the SVX keypad. The footprint is compatible to the SV9000 remote mount kit. Includes 10 ft cable, keypad holder and mounting hardware.	—	OPTRMT-KIT-9000X
Keypad Blank —9000X Series select keypad for use with special and custom applications.	—	KEYPAD-BLANK

Miscellaneous Options

Description	Catalog Number
9000XDrive —A PC-based tool for controlling and monitoring of the SVX. Features include: loading parameters that can be saved to a file or printed, setting references, starting and stopping the motor, monitoring signals in graphical or text form, and real-time display. To avoid damage to the drive or computer, SVDrivecable must be used.	9000XDRIVE
SVDrivecable —6 ft (1.8 m) RS-232 cable (22 gauge) with a 7-pin connector on each end. Should be used in conjunction with the 9000XDrive option to avoid damage to the SVX or computer. The same cable can be used for downloading specialized applications to the drive.	SVDRIVECABLE
External Dynamic Braking Resistors —Used with the dynamic braking chopper circuit to absorb motor regenerative energy for stopping the load and to dissipate the energy flowing back into the drive. Resistors are separated into standard duty and heavy-duty. Standard duty is defined as 20% duty or less with 100% braking torque, while heavy-duty is defined as 50% duty or less with 150% braking torque.	See Page V6-T2-269

SPX Drive Options

Brake Chopper Options

The brake chopper circuit option is used for applications that require dynamic braking. Dynamic braking resistors are not included with drive purchase. Consult the factory for additional dynamic braking resistor selections that are supplied separately. A list of common resistors are listed below and are complete indoor assemblies, include a pre-wired terminal block and a thermal switch, and are not UL Listed.

Duty Cycle

The duty cycle rating is based on a 60-second period. For example, the 20% duty cycle resistor can carry 100% current for 12 seconds out of every 60 seconds, while the 50% duty cycle resistor can carry 150% current for 30 seconds out of every 60 seconds.

Torque

If the braking torque required is less than 15%, dynamic braking is not required because the regenerated energy will be dissipated in the drive and motor losses.

Dynamic Brake Resistor—Catalog Number Selection

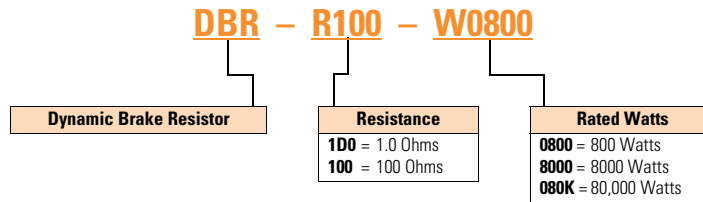

230 V Brake Resistors

Drive hp (CT/I _H)	Minimum Ohms	20% Duty Cycle, 100% Torque		50% Duty Cycle, 150% Torque	
		Catalog Number	Dimensions (Inches)	Catalog Number	Dimensions (Inches)
0.75	30.0	DBR-R100-W0400	12W x 5D x 5H	DBR-R100-W0800	12W x 7D x 5H
1	30.0	DBR-R100-W0400	12W x 5D x 5H	DBR-R100-W0800	12W x 7D x 5H
1.5	30.0	DBR-R100-W0400	12W x 5D x 5H	DBR-R036-W1200	12W x 10D x 5H
2	30.0	DBR-R100-W0400	12W x 5D x 5H	DBR-R036-W1200	12W x 10D x 5H
3	30.0	DBR-R036-W0800	12W x 7D x 5H	DBR-R036-W2000	12W x 16D x 5H
4	30.0	DBR-R036-W0800	12W x 7D x 5H	DBR-R030-W2400	19W x 10D x 5H
5	30.0	DBR-R036-W0800	12W x 7D x 5H	DBR-R030-W2800	19W x 13D x 5H
7.5	20.0	DBR-R020-W1200	12W x 10D x 5H	DBR-R020-W4800	26.5W x 13D x 5H
10	10.0	DBR-R015-W1600	12W x 13D x 5H	DBR-R112-W6000	26.5W x 13D x 5H
15	10.0	DBR-R012-W2400	19W x 10D x 5H	DBR-R010-W9000	28W x 10D x 10H
20	3.3	DBR-R9D3-W3200	19W x 10D x 5H	DBR-R3D4-W012K	28W x 10D x 10H
25	3.3	DBR-R5D5-W4000	26.5W x 10D x 5H	DBR-R5D1-W015K	28W x 16D x 10H
30	3.3	DBR-R4D8-W4800	26.5W x 10D x 5H	DBR-R4D1-W020K	28W x 16D x 10H
40	1.4	DBR-R004-W6000	26.5W x 13D x 5H	DBR-R3D4-W025K	30W x 18D x 16H
50	1.4	DBR-R3D1-W7500	26.5W x 16D x 5H	DBR-R2D1-W030K	30W x 18D x 24H
60	1.4	DBR-R2D8-W9000	26.5W x 16D x 5H	DBR-R002-W036K	30W x 18D x 24H
75	1.4	DBR-R2D6-W012K	28W x 10D x 10H	DBR-R1D5-W045K	30W x 18D x 32H
100	1.4	DBR-R002-W015K	28W x 16D x 10H	DBR-R1D4-W060K	30W x 18D x 40H

2.10

Adjustable Frequency Drives

SPX Drives

2

480 V Brake Resistors

Drive hp (CT/l _H)	Minimum Ohms	20% Duty Cycle, 100% Torque		50% Duty Cycle, 150% Torque	
		Catalog Number	Dimensions (Inches)	Catalog Number	Dimensions (Inches)
1	63.0	DBR-R100-W0400	12W x 5D x 5H	DBR-R100-W0800	12W x 7D x 5H
1.5	63.0	DBR-R100-W0400	12W x 5D x 5H	DBR-R100-W1200	12W x 10D x 5H
2	63.0	DBR-R100-W0400	12W x 5D x 5H	DBR-R100-W1200	12W x 10D x 5H
3	63.0	DBR-R100-W0800	12W x 7D x 5H	DBR-R100-W2000	12W x 16D x 5H
5	63.0	DBR-R100-W0800	12W x 7D x 5H	DBR-R100-W2800	19W x 13D x 5H
6	63.0	DBR-R100-W1200	12W x 10D x 5H	DBR-R070-W4000	19W x 16D x 5H
7.5	63.0	DBR-R100-W1200	12W x 10D x 5H	DBR-R063-W4800	26.5W x 13D x 5H
10	63.0	DBR-R063-W1600	12W x 13D x 5H	DBR-R063-W6000	26.5W x 16D x 5H
15	42.0	DBR-R042-W2400	19W x 10D x 5H	DBR-R042-W9000	28W x 10D x 10H
20	21.0	DBR-R030-W3200	19W x 13D x 5H	DBR-R023-W012K	28W x 13D x 10H
25	21.0	DBR-R030-W4000	19W x 16D x 5H	DBR-R021-W015K	28W x 13D x 10H
30	14.0	DBR-R020-W4800	26.5W x 13D x 5H	DBR-R014-W020K	30W x 18D x 24H
40	6.5	DBR-R112-W6000	26.5W x 13D x 5H	DBR-R007-W025K	30W x 18D x 16H
50	6.5	DBR-R013-W7500	26.5W x 16D x 5H	DBR-R8D5-W030K	30W x 18D x 24H
60	6.5	DBR-R010-W9000	28W x 10D x 10H	DBR-R7D3-W036K	30W x 18D x 24H
75	3.3	DBR-R009-W012K	28W x 13D x 10H	DBR-R3D3-W045K	30W x 18D x 32H
100	3.3	DBR-R5D1-W015K	28W x 16D x 10H	DBR-R004-W060K	30W x 18D x 40H
125	3.3	DBR-R4D1-W020K	28W x 16D x 10H	DBR-R004-W070K	30W x 18D x 48H
150	3.3	DBR-R3D4-W025K	30W x 18D x 16H	DBR-R3D5-W085K	30W x 18D x 56H
200	3.3	DBR-R3D3-W030K	30W x 18D x 24H	DBR-R3D3-W110K	30W x 18D x 72H
250	1.4	DBR-R2D5-W036K	30W x 18D x 24H	Ⓢ	—
300	1.4	DBR-R1D5-W045K	30W x 18D x 32H	Ⓢ	—
350	1.4	DBR-R1D4-W060K	30W x 18D x 40H	Ⓢ	—
400	0.9	DBR-R1D4-W060K	30W x 18D x 40H	Ⓢ	—
500	0.9	DBR-R0D9-W080K	30W x 18D x 48H	Ⓢ	—
550	0.9	DBR-R001-W085K	30W x 18D x 56H	Ⓢ	—

Note

Ⓢ Consult factory.

575 V Brake Resistors

Drive hp (CT/Hz)	Minimum Ohms	20% Duty Cycle, 100% Torque		50% Duty Cycle, 150% Torque	
		Catalog Number	Dimensions (Inches)	Catalog Number	Dimensions (Inches)
2	100.0	DBR-R100-W0400	12W x 5D x 5H	DBR-R100-W1200	12W x 10D x 5H
3	100.0	DBR-R100-W0800	12W x 7D x 5H	DBR-R100-W2000	12W x 16D x 5H
4	100.0	DBR-R100-W0800	12W x 7D x 5H	DBR-R100-W2400	19W x 10D x 5H
5	100.0	DBR-R100-W0800	12W x 7D x 5H	DBR-R100-W2800	19W x 13D x 5H
7.5	100.0	DBR-R100-W1200	12W x 10D x 5H	DBR-R100-W4800	26.5W x 13D x 5H
10	30.0	DBR-R063-W1600	12W x 13D x 5H	DBR-R063-W6000	26.5W x 16D x 5H
15	30.0	DBR-R042-W2400	19W x 10D x 5H	DBR-R042-W9000	28W x 10D x 10H
20	30.0	DBR-R030-W3200	19W x 13D x 5H	DBR-R030-W012K	28W x 13D x 10H
25	30.0	DBR-R030-W4000	19W x 16D x 5H	DBR-R030-W015K	28W x 16D x 10H
30	18.0	DBR-R020-W4800	26.5W x 13D x 5H	DBR-R020-W020K	30W x 18D x 16H
40	18.0	DBR-R030-W6000	26.5W x 16D x 5H	DBR-R184-W025K	30W x 18D x 16H
50	9.0	DBR-R013-W7500	26.5W x 16D x 5H	DBR-R012-W030K	30W x 18D x 24H
60	9.0	DBR-R010-W9000	28W x 10D x 10H	DBR-R010-W036K	30W x 18D x 24H
75	9.0	DBR-R009-W012K	28W x 13D x 10H	DBR-R009-W045K	30W x 18D x 24H
100	7.0	DBR-R013-W015K	28W x 16D x 10H	DBR-R8D4-W060K	30W x 18D x 40H
125	7.0	DBR-R8D2-W020K	30W x 18D x 10H	DBR-R007-W070K	30W x 18D x 40H
150	7.0	DBR-R007-W025K	30W x 18D x 16H	DBR-R006-W085K	30W x 18D x 56H
175	7.0	DBR-R007-W030K	30W x 18D x 24H	DBR-R007-W100K	30W x 18D x 72H
200	2.5	DBR-R3D3-W030K	30W x 18D x 24H	DBR-R2D6-W110K	30W x 18D x 64H
250	2.5	DBR-R2D5-W036K	30W x 18D x 24H	DBR-R003-W140K	30W x 18D x 72H
300	2.5	DBR-R3D3-W045K	30W x 18D x 32H	⊕	—
400	1.7	DBR-R002-W060K	30W x 18D x 48H	⊕	—
450	1.7	DBR-R1D8-W070K	30W x 18D x 48H	⊕	—
500	1.7	DBR-R002-W080K	30W x 18D x 56H	⊕	—

Note

⊕ Consult factory.

2.10

Adjustable Frequency Drives

SPX Drives

Control/Communication Options

Available Control/Communications Options

2

Option	Description	Option Type
K2	Door-Mounted Speed Potentiometer with HOA Selector Switch —Provides the SPX with the ability to start/stop and adjust the speed reference from door-mounted control devices or remotely from customer supplied inputs. In HAND position, the drive will start and the speed is controlled by the door-mounted speed potentiometer. The drive will be disabled in the OFF position. When AUTO is selected, the drive run and speed control commands are via user-supplied dry contact and 4–20 mA signal.	Control
K4	HAND/OFF/AUTO Switch for Non-Bypass Configurations —Provides a three-position selector switch that allows the user to select either a HAND or AUTO mode of operation. HAND mode is defaulted to keypad operation, and AUTO mode is defaulted to control from an external terminal source. These modes of operation can be configured via programming to allow for alternate combinations of start and speed sources. Start and speed sources include keypad, I/O and fieldbus.	Control
KB	115 V Control Transformer, 550 VA —Provides a fused control power transformer with additional 550 VA at 115 V for customer use.	Control
L1	Power On and Fault Pilot Lights —Provide a white power on light that indicates power to the enclosed cabinet and a red fault light that indicates a drive fault has occurred.	Light
P2	Disconnect Switch —Disconnect switch option is applicable only with NEMA Type 1/IP21 and NEMA Type 12/IP54 Freestanding drives. Allows a convenient means of disconnecting the SPX from the line, and the operating mechanism can be padlocked in the OFF position. This is factory-mounted in the enclosure.	Input

SPX Freestanding Options

480 V and 690 V Control Options, 200–550 hp ^①

Description	Catalog Number Suffix
Door-mounted speed potentiometer with HOA selector switch	K2
HAND/OFF/AUTO switch (22 mm)	K4
115 volt control transformer 550 VA	KB

480 V and 690 V Light Options, 200–550 hp ^①

Description	Catalog Number Suffix
Power on/fault pilot lights	L1

Input Options, 200–550 hp ^①

Description	Catalog Number Suffix
Disconnect switch	P2 ^②

Notes

^① Consult factory for adder information.

^② Applicable with FR10 and FR11 freestanding designs only.

Replacement Parts

FR4 Spare Parts

Category	Description	Quantity/ Drive	230 V Catalog Number	480 V Catalog Number	575 V Catalog Number
Control fan	NEMA Type 12 control fan ^①	1	PP01086	PP01086	—
Control module ^②	SPX control module	1	CPBS0000000000	CPBS0000000000	—
	Standard slot A I/O card	1	OPTA9	OPTA9	—
	Standard slot B I/O card	1	OPTA2	OPTA2	—
Keypad ^②	SVX/SPX keypad	1	KEYPAD-LOC/REM	KEYPAD-LOC/REM	—
Main fan ^②	DC fan (main)	1	PP01060	PP01060	—
Other	Mounting kit, fixing kit	1	FR00040	FR00040	—
	Mounting kit, fixing kit, N12 ^①	1	FR00079	FR00079	—
	Control cover, plastic, N1	1	FR00006	FR00006	—

FR5 Spare Parts

Category	Description	Quantity/ Drive	230 V Catalog Number	480 V Catalog Number	575 V Catalog Number
Control fan	NEMA Type 12 control fan ^①	1	PP01088	PP01088	—
Control module ^②	SPX control module	1	CPBS0000000000	CPBS0000000000	—
	Standard slot A I/O card	1	OPTA9	OPTA9	—
	Standard slot B I/O card	1	OPTA2	OPTA2	—
Keypad ^②	SVX/SPX keypad	1	KEYPAD-LOC/REM	KEYPAD-LOC/REM	—
Main fan ^②	DC fan (main)	1	PP01061	PP01061	—
Other	Mounting kit, fixing kit	1	FR00050	FR00050	—
	Mounting kit, fixing kit, N12 ^①	1	FR00081	FR00081	—
	Control cover, plastic, N1	1	FR05011	FR05011	—

FR6 Spare Parts

Category	Description	Quantity/ Drive	230 V Catalog Number	480 V Catalog Number	575 V Catalog Number
Control fan	NEMA Type 12 control fan ^①	1	PP01049	PP01049	—
Control module ^②	SPX control module	1	CPBS0000000000	CPBS0000000000	CPBS0000000000
	Standard slot A I/O card	1	OPTA9	OPTA9	OPTA9
	Standard slot B I/O card	1	OPTA2	OPTA2	OPTA2
Keypad ^②	SVX/SPX keypad	1	KEYPAD-LOC/REM	KEYPAD-LOC/REM	KEYPAD-LOC/REM
Main fan ^②	DC fan (main)	1	PP01062	PP01062	—
Other	Mounting kit, fixing kit	1	FR00060	FR00060	FR00060
	Mounting kit, fixing kit, N12 ^①	1	FR00082	FR00082	FR00082
	Control cover, plastic, N1	1	FR06011	FR06011	FR06011

FR7 Spare Parts

Category	Description	Quantity/ Drive	230 V Catalog Number	480 V Catalog Number	575 V Catalog Number
Control fan	NEMA Type 12 control fan ^①	1	PP01049	PP01049	PP01049
Control module ^②	SPX control module	1	CPBS0000000000	CPBS0000000000	CPBS0000000000
	Standard slot A I/O card	1	OPTA9	OPTA9	OPTA9
	Standard slot B I/O card	1	OPTA2	OPTA2	OPTA2
Keypad ^②	SVX/SPX keypad	1	KEYPAD-LOC/REM	KEYPAD-LOC/REM	KEYPAD-LOC/REM
Main fan ^②	DC fan (main)	1	PP01063	PP01063	PP01063
Other	Mounting kit, fixing kit	1	FR07071	FR07071	FR07071
	Mounting kit, fixing kit, N12 ^①	1	FR07072	FR07072	FR07072
	Control cover, plastic, N1	1	FR07011	FR07011	FR07011

Notes

^① Only for NEMA Type 12/IP54 Type drives.

^② Factory recommended spare parts.

2.10

Adjustable Frequency Drives

SPX Drives

2

FR8 Spare Parts

Category	Description	Quantity/ Drive	230 V Catalog Number	480 V Catalog Number	575 V Catalog Number
Control fan	NEMA Type 12 control fan ^①	1	CP01180	CP01180	CP01180
Control module ^②	SPX control module	1	CPBS0000000000	CPBS0000000000	CPBS0000000000
	Standard slot A I/O card	1	OPTA9	OPTA9	OPTA9
	Standard slot B I/O card	1	OPTA2	OPTA2	OPTA2
Keypad ^②	SVX/SPX keypad	1	KEYPAD-LOC/REM	KEYPAD-LOC/REM	KEYPAD-LOC/REM
Main AC fan	Fan AC	1	PP01123	PP01123	PP01123
	Fan fuse	2	PP20202	PP20202	PP20202
	Starting cap	1	S00734	S00734	S00734
	Fan driver board AC	1	VB00599	VB00799	VB00799
	Isolation transformer (fan)	1	S0000113	S0000113	S0000113
Main DC fan ^②	DC fan	1	PP00071	PP00071	PP00071
	DC power supply	1	S01016	S01016	S01016
Other	Front cover, N12 ^①	1	FR08079	FR08079	FR08079
	Conduit plate, N12	1	FR08082	FR08082	FR08082
	Front cover, N1	1	FR08106	FR08106	FR08106

FR9 Spare Parts

Category	Description	Quantity/ Drive	230 V Catalog Number	480 V Catalog Number	575 V Catalog Number
Control fan	50 mm fan	1	PP09041	PP09041	PP09041
	80 mm fan	1	PP01068	PP01068	PP01068
Control module ^①	SPX control module	1	CPBS0000000000	CPBS0000000000	CPBS0000000000
	Standard slot A I/O card	1	OPTA9	OPTA9	OPTA9
	Standard slot B I/O card	1	OPTA2	OPTA2	OPTA2
Converter	Power module ^②	1	FR09-0261-2-ANV	FR09-0261-4-ANV	FR09-0125-5-ANV
		1	FR09-0300-2-ANV	FR09-0300-4-ANV	FR09-0144-5-ANV
		1	—	—	FR09-0170-5-ANV
	Driver board	1	S00583	S00583	S00583
	Shunt board ^②	6	—	VB00535	VB00537
		6	—	VB00536	VB00542
6		—	—	VB00543	
DC section	Balancing resistor	3	PP00052	PP00052	PP00052
	Bus capacitor	8	S00335	S00335	PP01041
	DC busbars DC-	1	FR09043	FR09043	FR09043
	DC busbars DC+	1	FR09044	FR09044	FR09044
	DC busbars connection	1	FR09045	FR09045	FR09045
	DC busbars +/- insulator	1	FR09046	FR09046	FR09046
	DC busbars -/con insulator	1	FR09047	FR09047	FR09047
Inverter	Rectifier module	1	FR09826	FR09822	FR09823
	Diode	3	CP01268	CP01268	CP01268
	Rectifier board	1	—	VB00459	VB00460
Keypad ^①	SVX/SPX keypad	1	KEYPAD-LOC/REM	KEYPAD-LOC/REM	KEYPAD-LOC/REM
Main DC fan ^①	DC fan	1	PP00072	PP00072	PP00072
	DC power supply	1	S01017	S01017	S01017
Other	Front cover power	1	FR09012	FR09012	FR09012
	Front cover connection	1	FR09013	FR09013	FR09013
	Front power conduit	1	FR09014	FR09014	FR09014

Notes

- ① Only for NEMA Type 12/IP54 Type drives.
- ② Factory recommended spare parts.
- ③ Select one part number based on the amperage rating of the drive. Please contact EatonCare at 877-ETN-CARE for assistance.

FR10 Spare Parts

Category	Description	Quantity/ Drive	230 V Catalog Number	480 V Catalog Number	575 V Catalog Number
Control	Fiber board	1	—	S00451	S00451
	ASIC board	1	—	S00457	S00457
Control fan	ASIC fan	1	—	PP01096	PP01096
Control module ^①	SPX control module	1	—	CPBS0000000000	CPBS0000000000
	Standard slot A I/O card	1	—	OPTA9	OPTA9
	Standard slot B I/O card	1	—	OPTA2	OPTA2
Converter	Power module ^②	1	—	FR10-0385-4-ANV	FR10-0261-5-ANV
		1	—	FR10-0460-4-ANV	FR10-0325-5-ANV
		1	—	FR10-0520-4-ANV	FR10-0385-5-ANV
		1	—	—	FR10-0416-5-ANV
	Driver board	1	—	S00450	S00450
	Driver adapter board	1	—	VB00330	VB00330
	Shunt board ^②	6	—	VB00497	VB00510
		6	—	VB00498	VB00511
		6	—	VB00537	VB00545
	Covers	Top cover	1	—	FR10340
Side cover		2	—	FR10341	FR10341
DC section	Balancing resistor	2	—	PP13027	PP13028
	DC busbars kit (right)	1	—	S0000005	S0000005
	Bus capacitor	12	—	S00335	S00336
Inverter	Rectifier module	1	—	FR10823	FR10823
	Charging resistor	1	—	PP00066	PP00066
	Diode	3	—	PP01177	PP01177
	Rectifier board	1	—	S00591	S00592
Keypad ^①	SVX/SPX keypad	1	—	KEYPAD-LOC/REM	KEYPAD-LOC/REM
Main DC fan ^①	DC fan	2	—	PP00072	PP00072
	DC power supply	2	—	S01017	S01017

Notes

^① Factory recommended spare parts.

^② Select one part number based on the amperage rating of the drive. Please contact EatonCare at 877-ETN-CARE for assistance.

2.10

Adjustable Frequency Drives

SPX Drives

FR11 Spare Parts

2

Category	Description	Quantity/ Drive	230 V Catalog Number	480 V Catalog Number	575 V Catalog Number
Control	Fiber board	1	—	S00451	S00451
	ASIC board	1	—	S00457	S00457
Control fan	ASIC fan	1	—	PP01096	PP01096
Control module ①	SPX control module	1	—	CPBS0000000000	CPBS0000000000
	Standard slot A I/O card	1	—	OPTA9	OPTA9
	Standard slot B I/O card	1	—	OPTA2	OPTA2
Converter	Power module ②	1	—	FR11-0590-4-ANV	FR11-0460-5-ANV
		1	—	FR11-0650-4-ANV	FR11-0502-5-ANV
		1	—	FR11-0730-4-ANV	FR11-0590-5-ANV
	Driver board	1	—	S00452	S00452
	Driver adapter board	1	—	VB00330	VB00330
	Shunt board ②	9	—	VB00513	VB00512
		9	—	VB00514	VB00546
		9	—	VB00538	VB00547
	Covers	Top cover	1	—	FR11345
DC section	Balancing resistor	3	—	PP13027	PP13027
	DC busbars kit (right)	3	—	S0000005	S0000005
	Bus capacitor	18	—	S00335	S00335
Inverter	Rectifier module	1	—	FR10823	FR10823
	Diode	3	—	PP01177	PP01177
	Rectifier board	1	—	S00591	S00591
Keypad ①	SVX/SPX keypad	1	—	KEYPAD-LOC/REM	KEYPAD-LOC/REM
Main DC fan ①	DC fan	2	—	PP00072	PP00072
	DC power supply	2	—	S01017	S01017

Notes

① Factory recommended spare parts.

② Select one part number based on the amperage rating of the drive. Please contact EatonCare at 877-ETN-CARE for assistance.

FR12 Spare Parts

Category	Description	Quantity/ Drive	230 V Catalog Number	480 V Catalog Number	575 V Catalog Number
Control	Fiber board	2	—	S00451	S00451
	ASIC board	2	—	S00457	S00457
	Star coupler	1	—	S00593	S00593
Control fan	ASIC fan	2	—	PP01096	PP01096
Control module ^①	SPX control module	1	—	CPBS0000000000	CPBS0000000000
	Standard slot A I/O card	1	—	OPTA9	OPTA9
	Standard slot B I/O card	1	—	OPTA2	OPTA2
Converter	Power module ^②	1	—	FR12-0820-4-ANV	FR12-0650-5-ANV
		1	—	FR12-0920-4-ANV	FR12-0750-5-ANV
		1	—	FR12-1030-4-ANV	FR12-0820-5-ANV
	Driver board	2	—	S00450	S00450
	Driver adapter board	2	—	VB00330	VB00330
	Shunt board	12	—	VB00498	VB00511
	Covers	Top cover	2	—	FR10340
Side cover		4	—	FR10341	FR10341
DC section	Balancing resistor	4	—	PP13027	PP13027
	DC busbars kit (right)	2	—	S0000005	S0000005
	Bus capacitor	24	—	S00335	S00336
Inverter	Rectifier module	2	—	FR10823	FR10823
	Diode	3	—	PP01177	PP01177
	Rectifier board	2	—	S00591	S00591
Keypad ^①	SVX/SPX keypad	1	—	KEYPAD-LOC/REM	KEYPAD-LOC/REM
Main DC fan ^①	DC fan	4	—	PP00072	PP00072
	DC power supply	4	—	S01017	S01017

Notes

^① Factory recommended spare parts.

^② Select one part number based on the amperage rating of the drive. Please contact EatonCare at 877-ETN-CARE for assistance.

2.10

Adjustable Frequency Drives

SPX Drives

FR13 Spare Parts

2

Category	Description	Quantity/ Drive	230 V Catalog Number	480 V Catalog Number	575 V Catalog Number
Control	ASIC board	1	—	S00457	S00457
	ASIC assembly	1	—	60S01030	60S01030
Control fan	ASIC fan	1	—	PP01096	PP01096
Control module ①	SPX control module	1	—	CPBS0000000000	CPBS0000000000
	Standard slot A I/O card	1	—	OPTA9	OPTA9
	Standard slot B I/O card	1	—	OPTA2	OPTA2
Converter	Power module ②	3	—	FI13-1150-4-ANV	FR13-1030-5-ANV
		3	—	FI13-1300-4-ANV	FR13-1180-5-ANV
		3	—	FI13-1450-4-ANV	FR13-920-5-ANV
	Driver board	3	—	S00454	S00454
	Driver adapter board	2	—	VB00330	VB00330
	Shunt board ②	18	—	VB00505	VB00516
		18	—	VB00514	VB00517
		18	—	VB00541	VB00547
Covers	Top cover	3	—	FI10001	FI10001
	Side cover	3	—	FI10003	FI10003
DC section	Balancing resistor	6	—	PP13034	PP13034
	Bus capacitor	36	—	S00335	S00336
	DC busbars kit	3	—	FI13329	FI13329
Inverter	Rectifier module	2	—	FR10823	FR10823
	Diode	3	—	PP01177	PP01177
	Rectifier board	2	—	S00591	S00591
Keypad ①	SVX/SPX keypad	1	—	KEYPAD-LOC/REM	KEYPAD-LOC/REM
Main DC fan ①	DC fan	4	—	PP00072	PP00072
	DC power supply	4	—	S01017	S01017

Notes

① Factory recommended spare parts.

② Select one part number based on the amperage rating of the drive. Please contact EatonCare at 877-ETN-CARE for assistance.

FR14 Spare Parts

Category	Description	Quantity/ Drive	230 V Catalog Number	480 V Catalog Number	575 V Catalog Number
Control	ASIC board	2	—	S00457	S00457
	Star coupler	1	—	S00593	S00593
	ASIC assembly	2	—	60S01030	60S01030
	Star coupler kit	1	—	FR10860	FR10860
Control fan	ASIC fan	2	—	PP01096	PP01096
Control module ^①	SPX control module	1	—	CPBS0000000000	CPBS0000000000
	Standard slot A I/O card	1	—	OPTA9	OPTA9
	Standard slot B I/O card	1	—	OPTA2	OPTA2
Converter	Power module ^②	1	—	FR14-1770-4-ANV	FR14-1500-5-ANV
		1	—	FR14-2150-4-ANV	FR14-1900-5-ANV
		1	—	FR14-2700-4-ANV	FR14-2250-5-ANV
	Driver board	6	—	S00454	S00454
	Driver adapter board	2	—	VB00330	VB00330
	Shunt board ^②	36	—	VB00541	VB00516
		36	—	—	VB00517
Covers	Top cover	6	—	FI10001	FI10001
	Side cover	6	—	FI10003	FI10003
DC section	Balancing resistor	6	—	PP13034	PP13034
	Bus capacitor	72	—	S00335	S00336
	DC busbars kit	6	—	FI13329	FI13329
Inverter	Rectifier module	2	—	FR10823	FR10823
	Diode	3	—	PP01177	PP01177
	Rectifier board	2	—	S00591	S00591
Keypad ^①	SVX/SPX keypad	1	—	KEYPAD-LOC/REM	KEYPAD-LOC/REM
Main DC fan ^①	DC fan	6	—	PP00072	PP00072
	DC power supply	6	—	S01017	S01017

Notes

^① Factory recommended spare parts.

^② Select one part number based on the amperage rating of the drive. Please contact EatonCare at 877-ETN-CARE for assistance.

Technical Data and Specifications

2

SPX Drives

Description	Specification
Input Ratings	
Input voltage (V_{in})	+10%/–15%
Input frequency (f_{in})	50/60 Hz (variation up to 45–66 Hz)
Connection to power	Once per minute or less (typical operation)
High withstand rating	100 kAIC
Output Ratings	
Output voltage	0 to V_{in}
Continuous output current	I_H rated 100% at 122 °F (50 °C), FR9 and below I_L rated 100% at 104 °F (40 °C), FR9 and below I_H/I_L 100% at 104 °F (40 °C), FR10 and above
Overload current (I_H/I_L)	150% I_H , 110% I_L for 1 min.
Output frequency	0 to 320 Hz
Frequency resolution	0.01 Hz
Initial output current (I_H)	250% for 2 seconds
Efficiency	>96%
Control Characteristics	
Control method	Frequency control (V/f) Open loop: sensorless vector control Closed loop: frequency control Closed loop: vector control
Switching frequency	Adjustable with parameter 2.6.9
Frame 4–6	1 to 16 kHz; default 10 kHz
Frame 7–12	1 to 10 kHz; default 3.6 kHz
Frequency reference	Analog input: Resolution 0.1% (10-bit), accuracy $\pm 1\%$ V/Hz Panel reference: Resolution 0.01 Hz
Field weakening point	30 to 320 Hz
Acceleration time	0 to 3000 sec.
Deceleration time	0 to 3000 sec.
Braking torque	DC brake: 30% $\times T_n$ (without brake option)
Ambient Conditions	
Ambient operating temperature	14 °F (–10 °C), no frost to 122 °F (50 °C) I_H (FR4–FR9) 14 °F (–10 °C), no frost to 104 °F (40 °C) I_L (FR10 and up) 14 °F (–10 °C), no frost to 104 °F (40 °C) I_L (all frames)
Storage temperature	–40° to 158 °F (–40° to 70 °C)
Relative humidity	0 to 95% RH, noncondensing, non-corrosive, no dripping water
Air quality	Chemical vapors: IEC 721-3-3, unit in operation, class 3C2; Mechanical particles: IEC 721-3-3, unit in operation, class 3S2
Altitude	100% load capacity (no derating) up to 3280 ft (1000 m); 1% derating for each 328 ft (100 m) above 3280 ft (1000 m); max. 9842 ft (3000 m)
Vibration	EN 50178, EN 60068-2-6; 5 to 50 Hz, displacement amplitude 1 mm (peak) at 3 to 15.8 Hz, max. acceleration amplitude 1G at 15.8 to 150 Hz
Shock	EN 50178, EN 60068-2-27 UPS Drop test (for applicable UPS weights) Storage and shipping: max. 15 g, 11 ms (in package)
Enclosure class	NEMA 1/IP21 or NEMA 12/IP54, open chassis/IP20

Description	Specification
Control Connections	
Analog input voltage	0 to 10 V, R = 200 kohms (–10 to 10 V joystick control) resolution 0.1%; accuracy $\pm 1\%$
Analog input current	0(4) to 20 mA; R_i —250 ohms differential
Digital inputs (6)	Positive or negative logic; 18 to 30 Vdc
Auxiliary voltage	+24 V $\pm 15\%$, max. 250 mA
Output reference voltage	+10 V +3%, max. load 10 mA
Analog output	0(4) to 20 mA; R_L max. 500 ohms; resolution 10 bit; Accuracy $\pm 2\%$
Digital outputs	Open collector output, 50 mA/48V
Relay outputs	2 programmable Form C relay outputs switching capacity: 24 Vdc/8 A, 250 Vac/8 A, 125 Vdc/0.4 A
Protections	
Overcurrent protection	Trip limit 4.0 $\times I_H$ instantaneously
Overvoltage protection	Yes
Undervoltage protection	Yes
Earth fault protection	In case of earth fault in motor or motor cable, only the frequency converter is protected
Input phase supervision	Trips if any of the input phases are missing
Motor phase supervision	Trips if any of the output phases are missing
Overtemperature protection	Yes
Motor overload protection	Yes
Motor stall protection	Yes
Motor underload protection	Yes
Short-circuit protection	Yes (+24 V and +10 V reference voltages)
High Performance Features	
Speed error	<0.01%, depending on the encoder
Encoder support	Incremental or absolute
Encoder voltages	5 V (RS-422), 15 V or 24 V, depending on the option card
Torque control	Full torque control at all speeds, including zero
Torque accuracy	<2%; <5% down to zero speed
Starting torque	>200%, depending on motor and drive sizing
Master/slave configurations	Full capability
System analysis	Integrated data logger
PC communication	Fast multiple drive monitoring with PC
Inter-drive communication	High-speed bus (12 Mbits/s)
High-speed applications	Up to 7200 Hz (special software required)

Dimensions

Approximate Dimensions in Inches (mm)

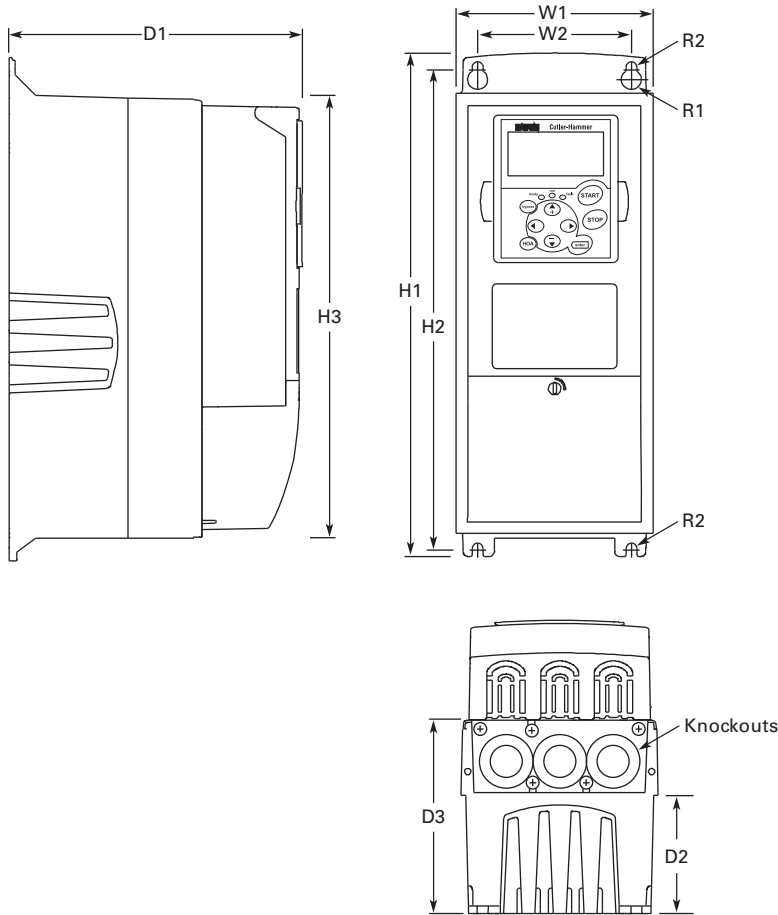
9000X Drives**NEMA Type 1/IP21 and NEMA Type 12/IP54, FR4, FR5 and FR6**

Voltage	hp (I _H)	H1	H2	H3	D1	D2	D3	W1	W2	R1 Dia.	R2 Dia.	Weight Lbs (kg)	Knockouts at Inches (mm)
FR4													
230 V	3/4–3	12.9	12.3	11.5	7.5	3.0	5.0	5.04	3.9	0.5	0.3	11.0 (5)	3 at 10.1 (28)
480 V	1–5	(327)	(313)	(292)	(190)	(77)	(126)	(128)	(100)	(13)	(7)		
FR5													
230 V	5–7-1/2	16.5	16.0	15.3	8.4	3.9	5.8	5.7	3.9	0.5	0.3	17.9 (8)	2 at 1.5 (37)
480 V	7-1/2–15	(419)	(406)	(389)	(214)	(100)	(148)	(144)	(100)	(13)	(7)		1 at 10.1 (28)
FR6													
230 V	10–15	22.0	21.3	20.4	9.3	4.2	6.5	7.7	5.8	0.6	0.4	40.8 (19)	3 at 1.5 (37)
480 V	20–30	(558)	(541)	(519)	(237)	(105)	(165)	(195)	(148)	(15.5)	(9)		
575 V	2–25												

2.10 Adjustable Frequency Drives

SPX Drives

Approximate Dimensions in Inches (mm)

NEMA Type 1/IP21 and NEMA Type 12/IP54 with Flange Kit, FR4, FR5 and FR6

2

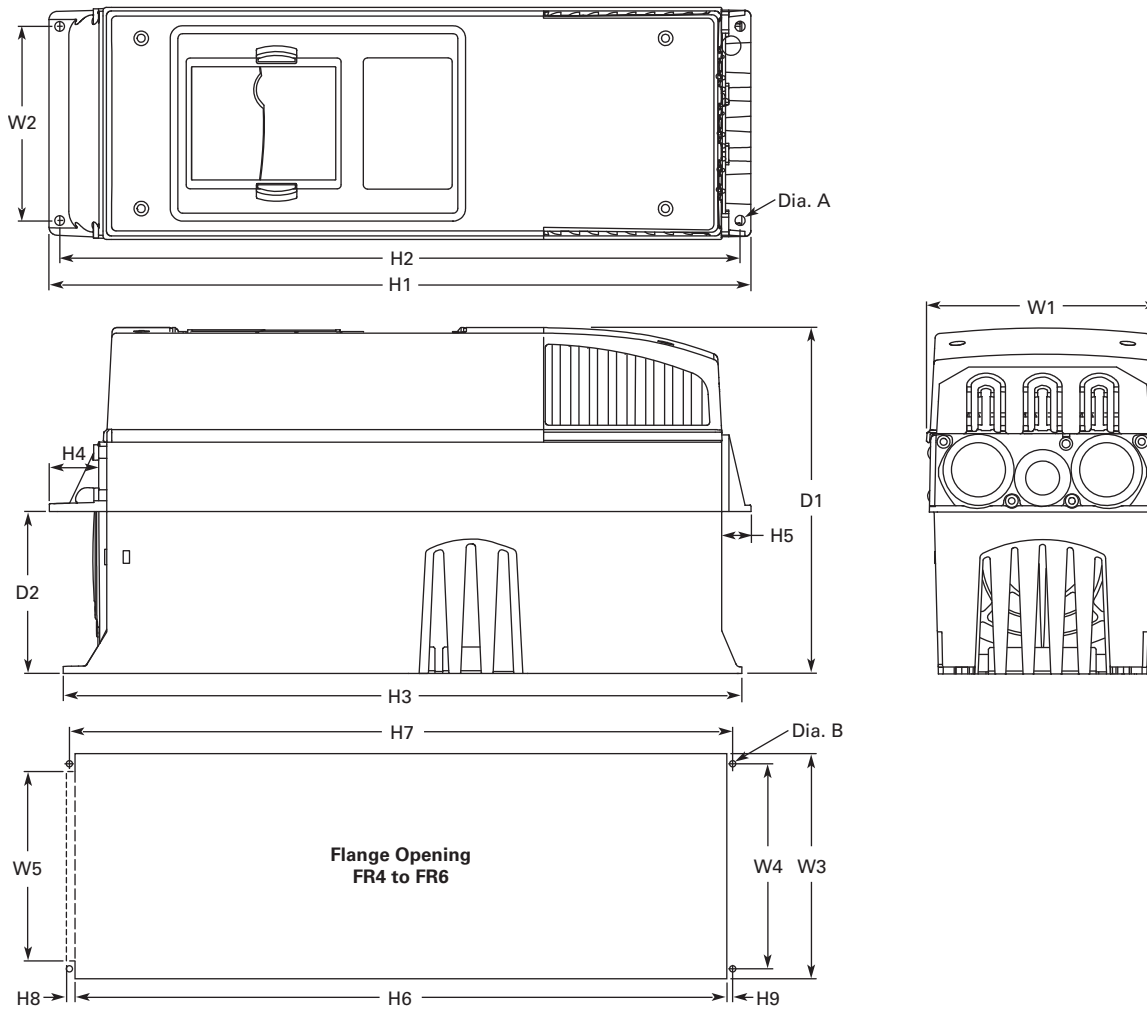

FR4, FR5 and FR6 with Flange Kit

W1	W2	H1	H2	H3	H4	H5	D1	D2	Dia. A
FR4									
5.0 (128)	4.5 (113)	13.3 (337)	12.8 (325)	12.9 (327)	1.2 (30)	0.9 (22)	7.5 (190)	3.0 (77)	0.3 (7)
FR5									
5.6 (143)	4.7 (120)	17.0 (434)	16.5 (420)	16.5 (419)	1.4 (36)	0.7 (18)	8.4 (214)	3.9 (100)	0.3 (7)
FR6									
7.7 (195)	6.7 (170)	22.0 (560)	21.6 (549)	22.0 (558)	1.2 (30)	0.8 (20)	9.3 (237)	4.2 (106)	0.3 (7)

Flange Opening, FR4 to FR6

W3	W4	W5	H6	H7	H8	H9	Dia. B
FR4							
4.8 (123)	4.5 (113)	—	12.4 (315)	12.8 (325)	—	0.2 (5)	0.3 (7)
FR5							
5.3 (135)	4.7 (120)	—	16.2 (410)	16.5 (420)	—	0.2 (5)	0.3 (7)
FR6							
7.3 (185)	6.7 (170)	6.2 (157)	21.2 (539)	21.6 (549)	0.3 (7)	0.2 (5)	0.3 (7)

Approximate Dimensions in Inches (mm)

NEMA Type 1/IP21 and NEMA Type 12/IP54, FR7

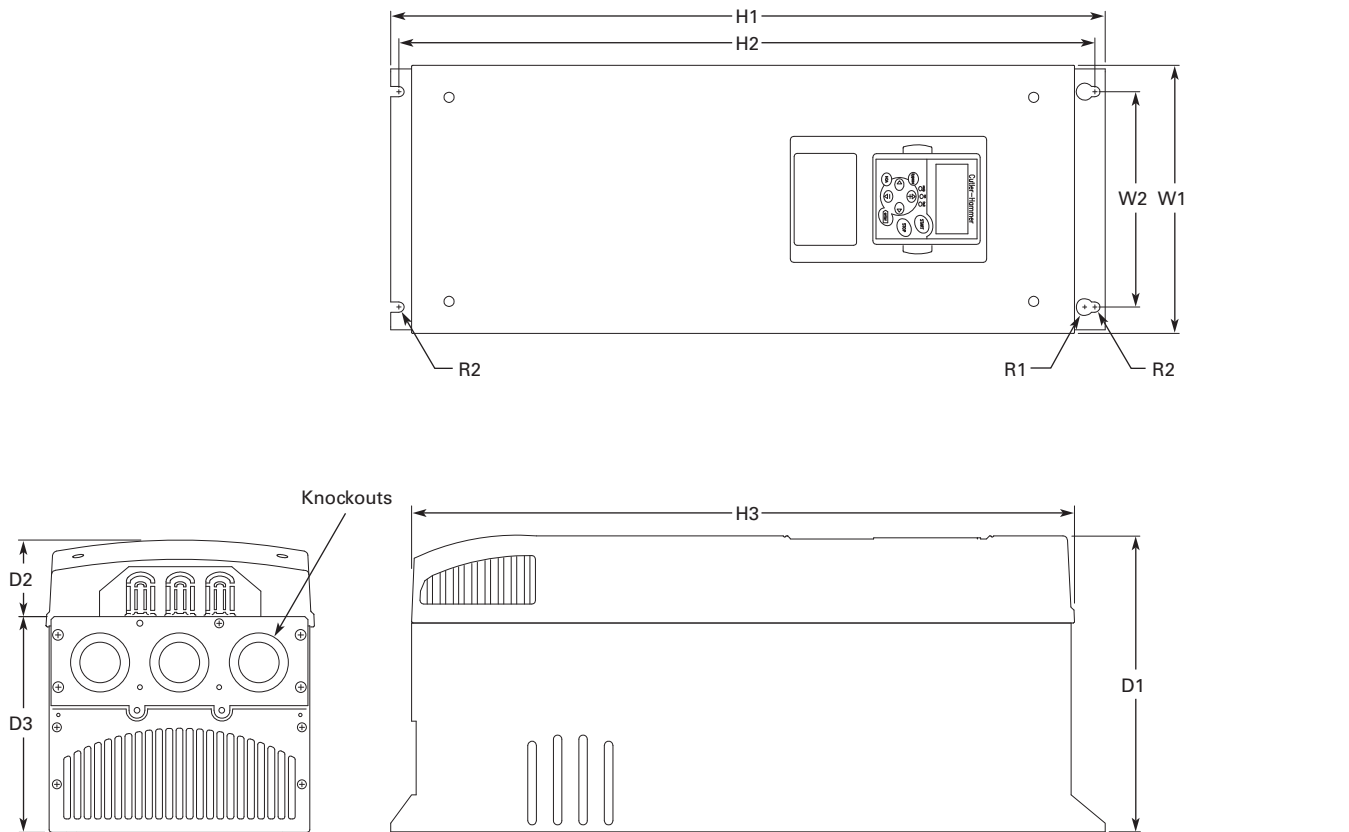

Voltage	hp (I _H)	H1	H2	H3	D1	D2	D3	W1	W2	R1 Dia.	R2 Dia.	Weight Lbs (kg)	Knockouts at Inches (mm) N1 (O.D.)
230 V	20–30	24.8 (630)	24.2 (614)	23.2 (590)	10.1 (257)	3.0 (77)	7.3 (184)	9.3 (237)	7.5 (190)	0.7 (18)	0.4 (9)	77.2 (35)	3 at 1.5 (37)
480 V	40–60												
575 V	30–40												

2.10 Adjustable Frequency Drives

SPX Drives

Approximate Dimensions in Inches (mm)

NEMA Type 1/IP21 and NEMA Type 12/IP54, FR8

2

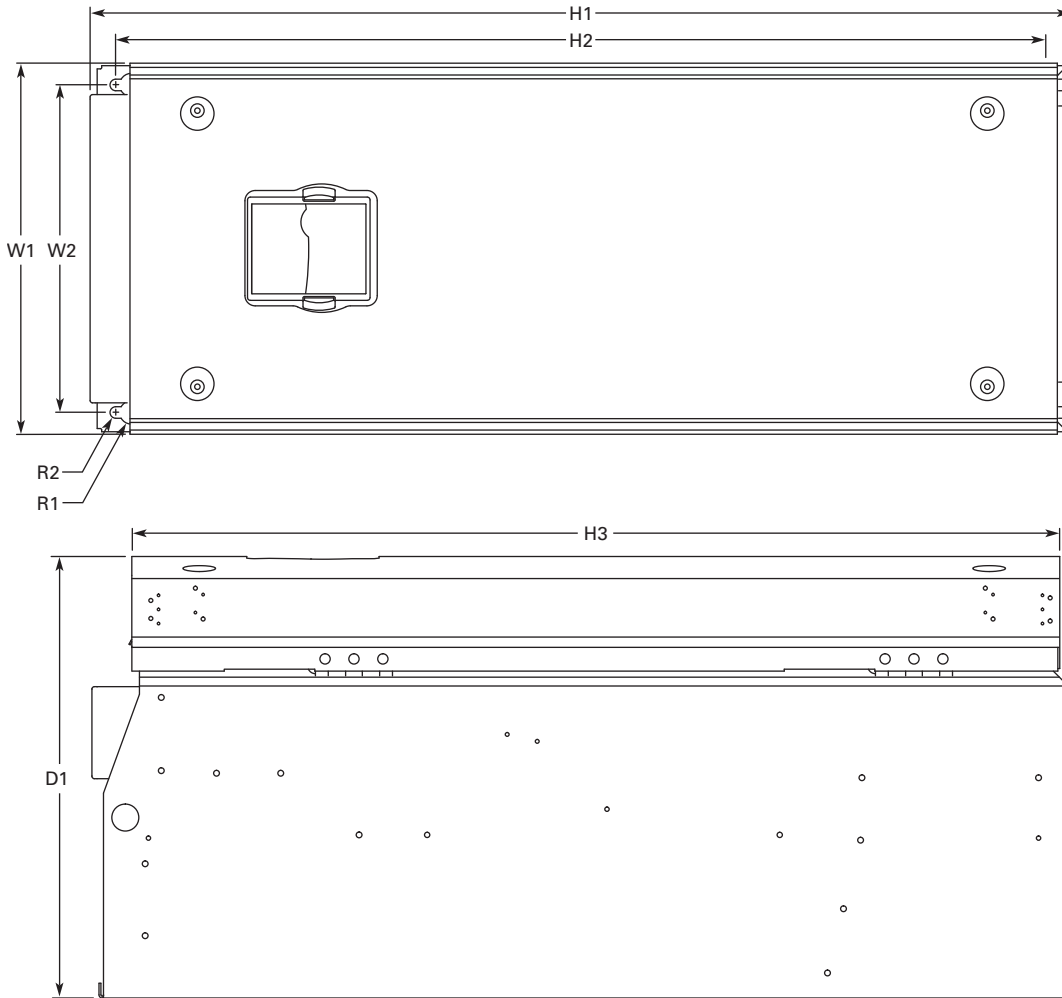

Voltage	hp (I _H)	D1	H1	H2	H3	W1	W2	R1 Dia.	R2 Dia.	Weight Lbs (kg)
230 V	40–60	13.5 (344)	30.1 (764)	28.8 (732)	28.4 (721)	11.5 (291)	10 (255)	0.7 (18)	0.4 (9)	127 (58)
480 V	75–125									
575 V	50–75									

Approximate Dimensions in Inches (mm)

NEMA Type 1/IP21 and NEMA Type 12/IP54, with Flange Kit, FR7 and FR8

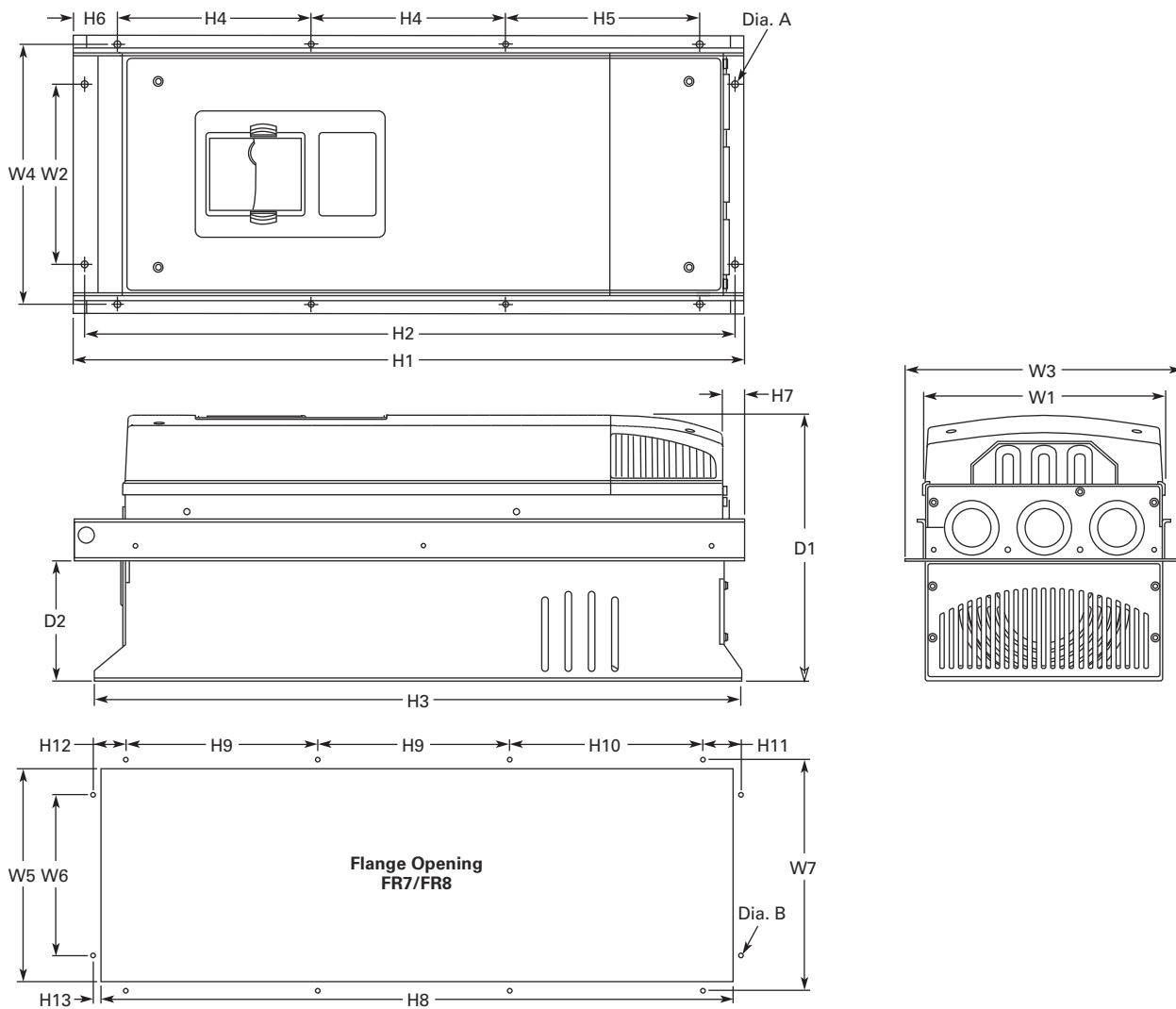

W1	W2	W3	W4	H1	H2	H3	H4	H5	H6	H7	D1	D2	Dia. A
FR7													
9.3 (237)	6.8 (175)	10.6 (270)	10.0 (253)	25.6 (652)	24.9 (632)	24.8 (630)	7.4 (189)	7.4 (189)	0.9 (23)	0.8 (20)	10.1 (257)	4.6 (117)	0.3 (6)
FR8													
11.2 (285)	—	14.0 (355)	13.0 (330)	32.8 (832)	—	29.3 (745)	10.2 (258)	10.4 (265)	1.7 (43)	2.2 (57)	13.5 (344)	4.3 (110)	0.4 (9)

Flange Opening, FR7 and FR8

W5	W6	W7	H8	H9	H10	H11	H12	H13	Dia. B
FR7									
9.2 (233)	6.9 (175)	10.0 (253)	24.4 (619)	7.4 (189)	7.4 (189)	1.4 (35)	1.3 (32)	1.0 (25)	0.3 (6)
FR8									
11.9 (301)	—	13.0 (330)	31.9 (810)	10.2 (258)	10.4 (265)	—	—	1.3 (33)	0.4 (9)

2.10 Adjustable Frequency Drives

SPX Drives

Approximate Dimensions in Inches (mm)

NEMA Type 1/IP21 and NEMA Type 12/IP54, FR9

2

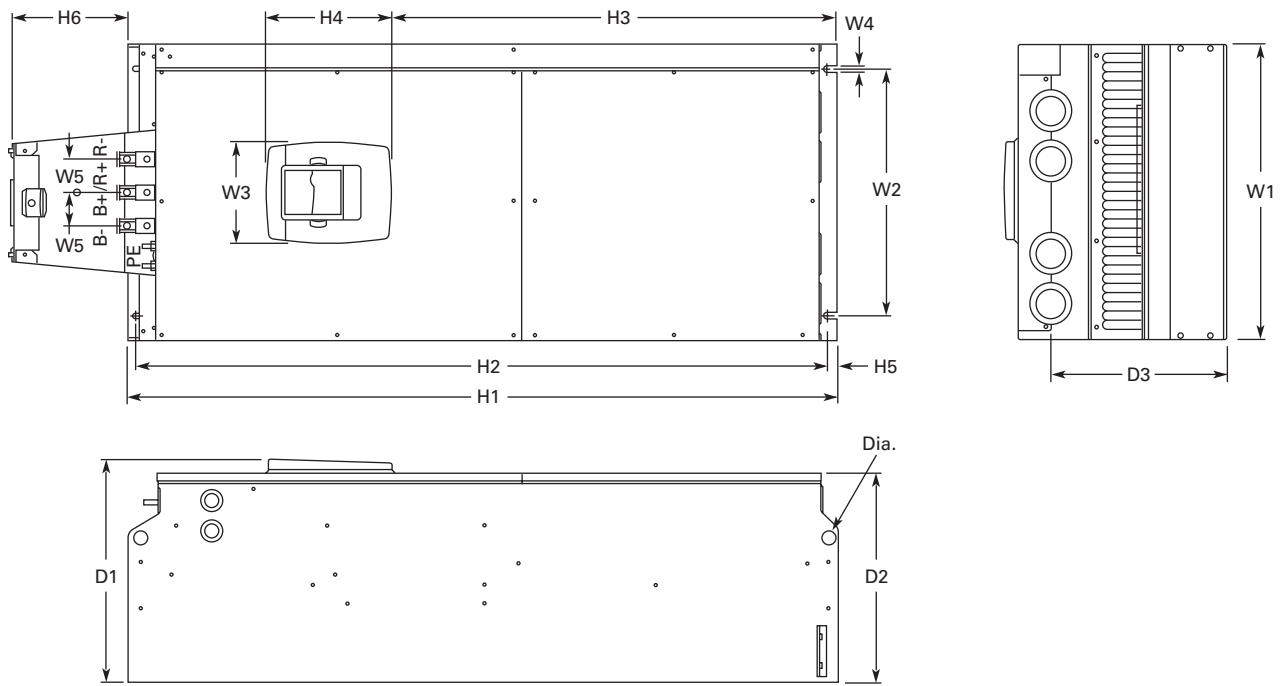

Voltage	hp (I _H)	W1	W2	W3	W4	H1	H2	H3	H4 ①	D1	D2	D3	Dia.	Weight Lbs (kg)
230 V	75–100	18.9 (480)	15.7 (400)	0.4 (9)	2.1 (54)	45.3 (1150)	44.1 (1120)	0.6 (16)	7.4 (188)	14.2 (361.5)	13.4 (340)	11.2 (285)	0.8 (21)	321.9 (146)
480 V	150–200													
575 V	100–175													

Note

① Brake resistor terminal box (H6) included when brake chopper ordered.

Approximate Dimensions in Inches (mm)

NEMA Type 1/IP21 and NEMA Type 12/IP54, FR9 with Flange Kit

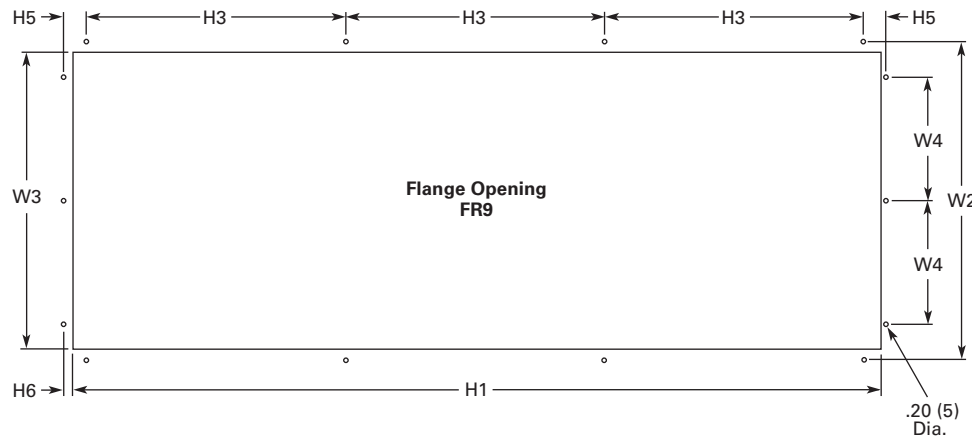
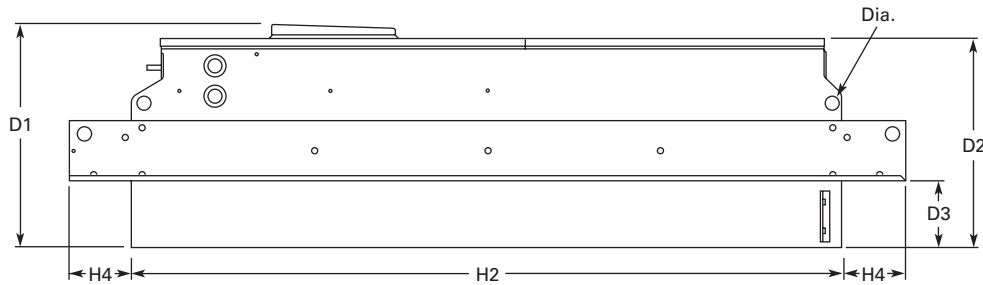
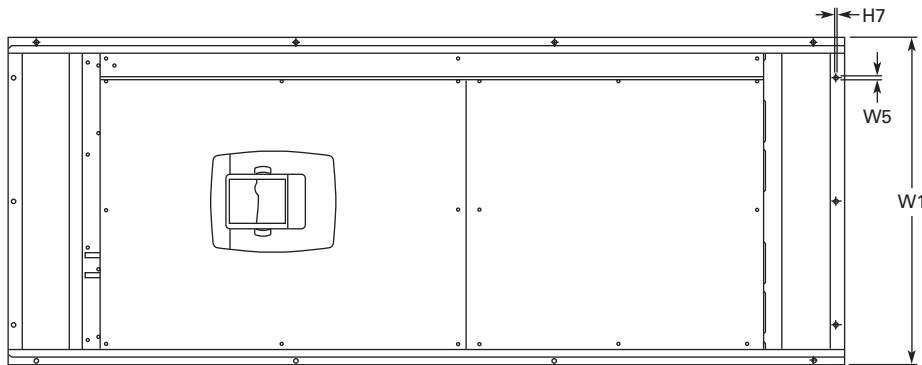

W1	W2	W3	W4	W5	H1	H2	H3	H4	H5	H6	H7	D1	D2	D3	Dia.
20.9 (530)	20.0 (510)	19.1 (485)	7.9 (200)	0.2 (5.5)	51.7 (1312)	45.3 (1150)	16.5 (420)	3.9 (100)	1.4 (35)	0.4 (9)	0.1 (2)	24.9 (362)	13.4 (340)	4.3 (109)	0.8 (21)

2.10 Adjustable Frequency Drives

SPX Drives

Approximate Dimensions in Inches (mm)

NEMA Type 1/IP21 and NEMA Type 12/IP54, FR10 Freestanding

2

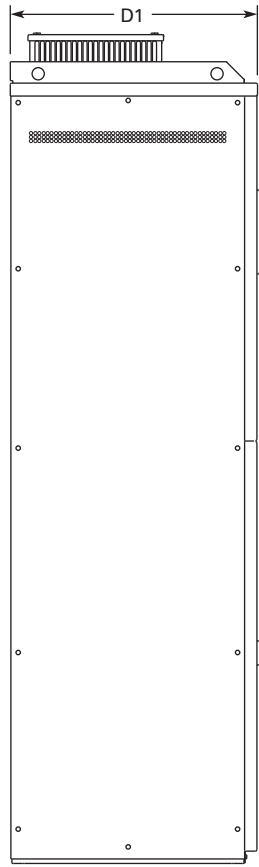
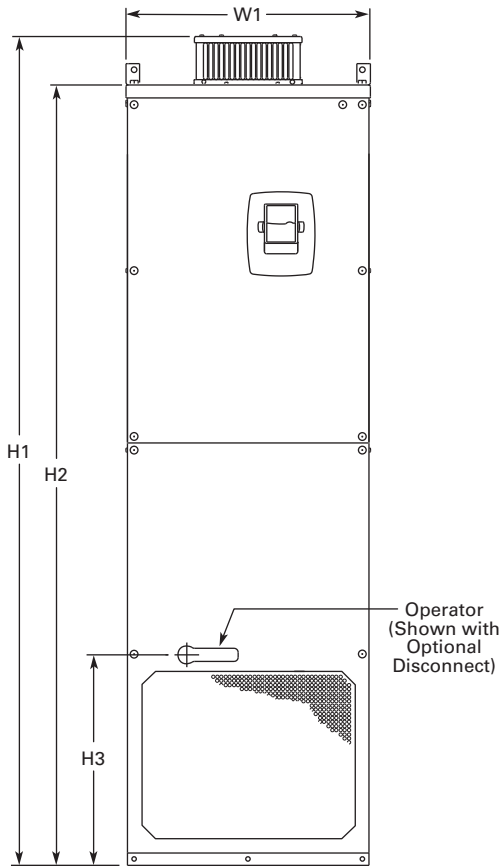
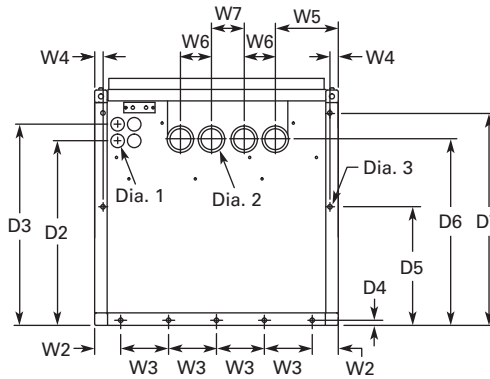
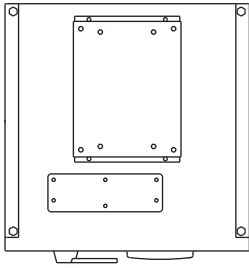

Volts	hp (I _H)	W1	W2	W3	W4	W5	W6	W7	H1	H2	H3	D1	D2	D3	D4	D5	D6	D7	Dia. 1	Dia. 2	Dia. 3	Weight Lbs (kg)
480 V	250–350	23.43	2.46	4.53	0.79	5.95	2.95	30.11	79.45	74.80	20.18	23.70	17.44	19.02	0.47	11.22	17.60	20.08	0.83	1.89	0.43	875 (389)
690 V	200–300	(595)	(62.5)	(115)	(20)	(151)	(75)	(79)	(2018)	(1900)	(512.5)	(602)	(443)	(483)	(12)	(285)	(447)	(510)	(21)	(48)	(11)	

Approximate Dimensions in Inches (mm)

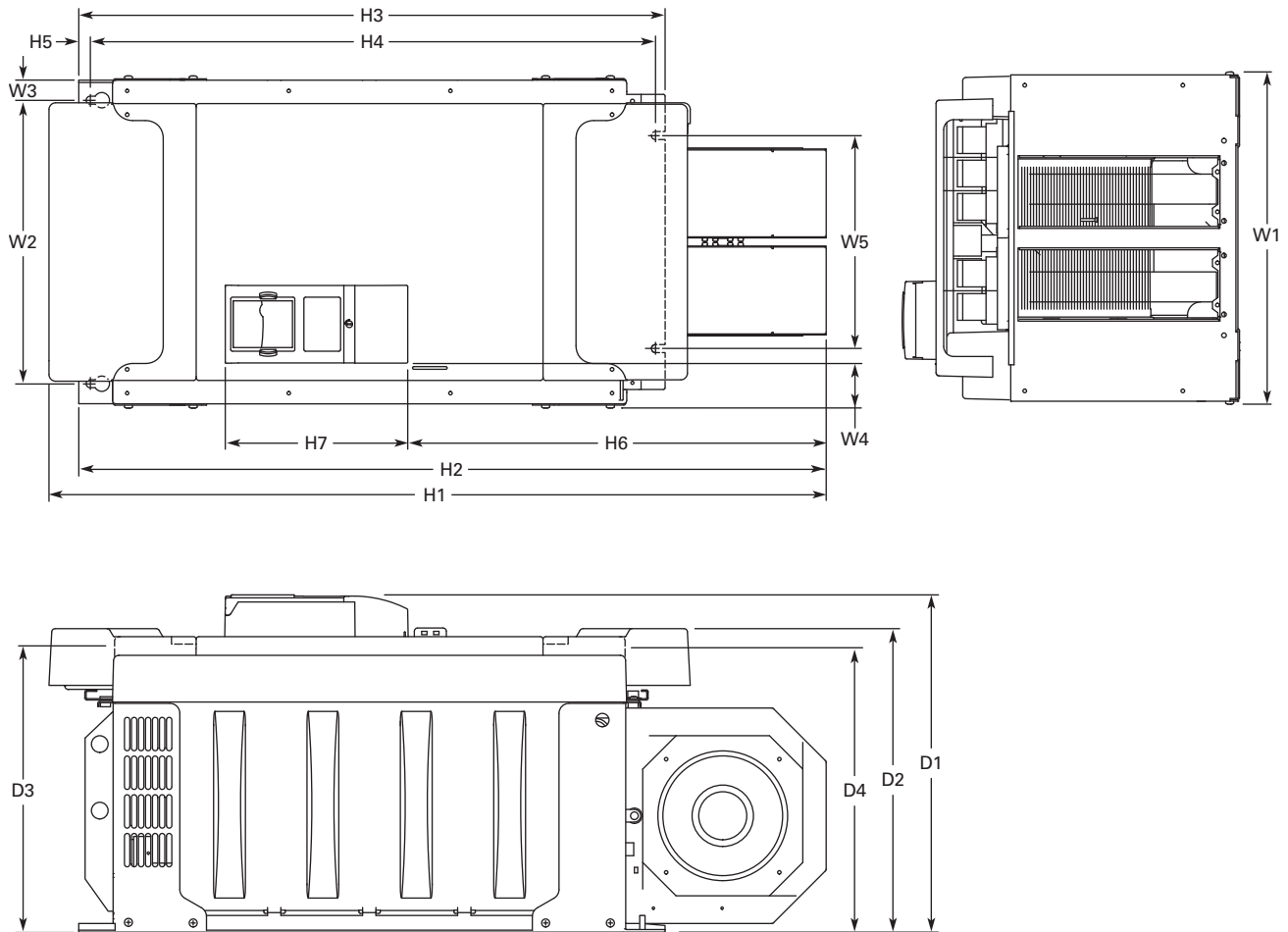
FR10 Open Chassis ①

Voltage	hp (I _H)	W1	W2	W3	W4	W5	H1	H2	H3	H4	H5	H6	H7	D1	D2	D3	D4	Weight Lbs (kg)
480 V	250–350	19.7 (500)	16.7 (425)	1.2 (30)	2.6 (67)	12.8 (325)	45.9 (1165)	44.1 (1121)	34.6 (879)	33.5 (850)	0.7 (17)	24.7 (627)	10.8 (275)	19.9 (506)	17.9 (455)	16.7 (423)	16.6 (421)	518 (235)
575 V	200–300																	

Note

① SPXX FR12 is built of two FR10 modules. Please refer to SPX installation manual for mounting instructions.

2.10 Adjustable Frequency Drives

SPX Drives

Approximate Dimensions in Inches (mm)

NEMA Type 1/IP21, FR11 Freestanding Drive

2

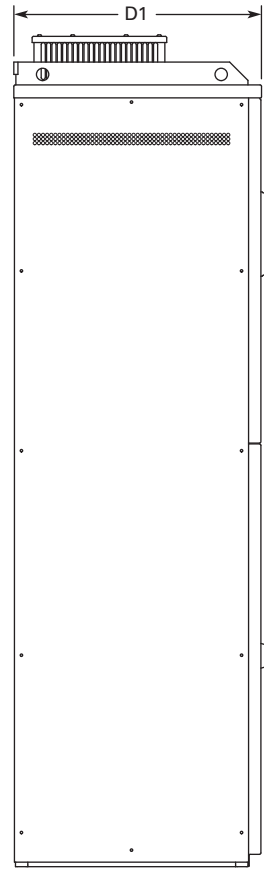
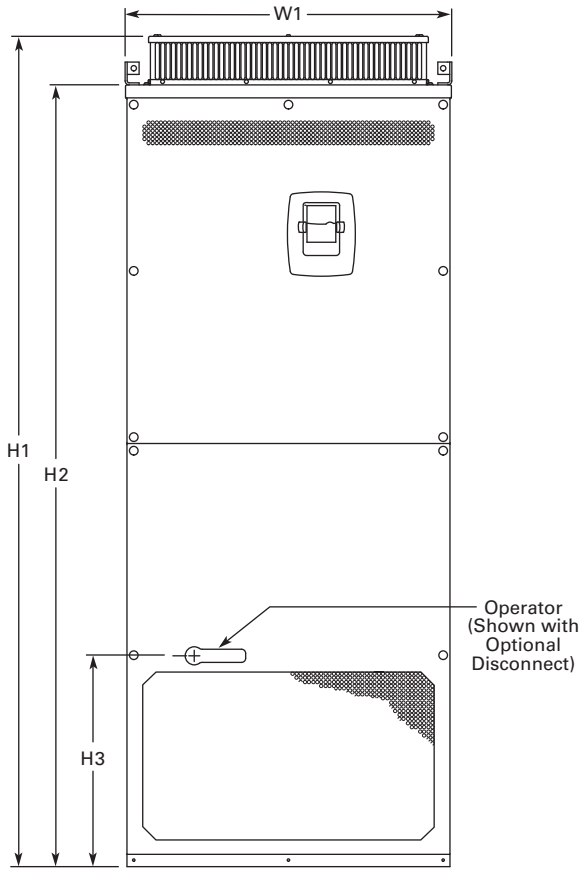
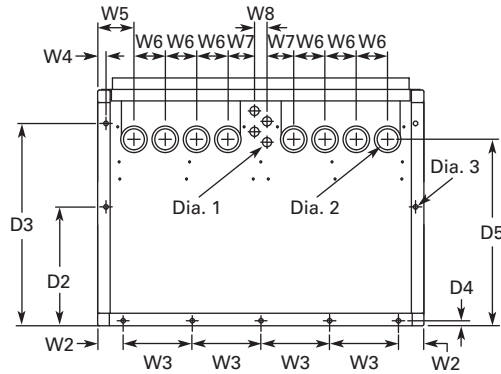
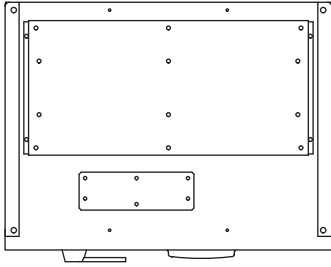

Voltage	hp (I _H)	W1	W2	W3	W4	W5	W6	W7	W8	H1	H2	H3	D1	D2	D3	D4	D5	Dia. 1	Dia. 2	Dia. 3	Weight Lbs (kg)
480 V	400–550	31.26	2.40	6.50	0.79	3.43	2.95	2.52	1.18	79.45	74.80	20.18	23.70	11.22	19.09	0.47	17.60	0.83	1.89	0.35 x 0.43	526
		(794)	(61)	(165)	(20)	(87)	(75)	(64)	(30)	(2018)	(1900)	(512.5)	(602)	(285)	(485)	(12)	(447)	(21)	(48)	(9 x 11)	(239)
690 V	400–500																				

Approximate Dimensions in Inches (mm)

FR11 Open Chassis

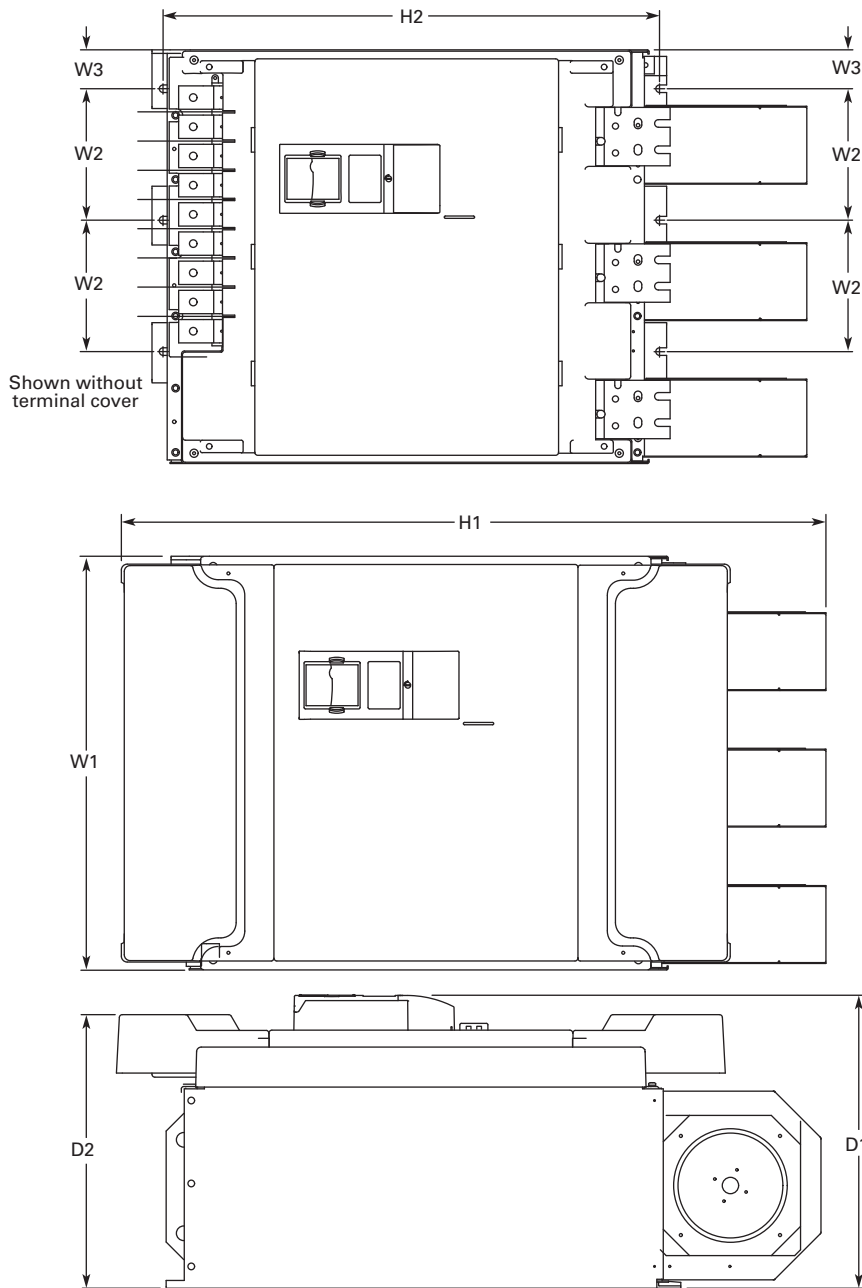

Voltage	hp (I _H)	W1	W2	W3	H1	H2	D1	D2	Weight Lbs (kg)
480 V	400–550	27.9 (709)	8.6 (225)	2.6 (67)	45.5 (1155)	33.5 (850)	19.8 (503)	18.4 (468)	833 (378)
575 V	400–500								

2.10 Adjustable Frequency Drives

SPX Drives

Approximate Dimensions in Inches (mm)

FR13, Open Chassis Inverter

2

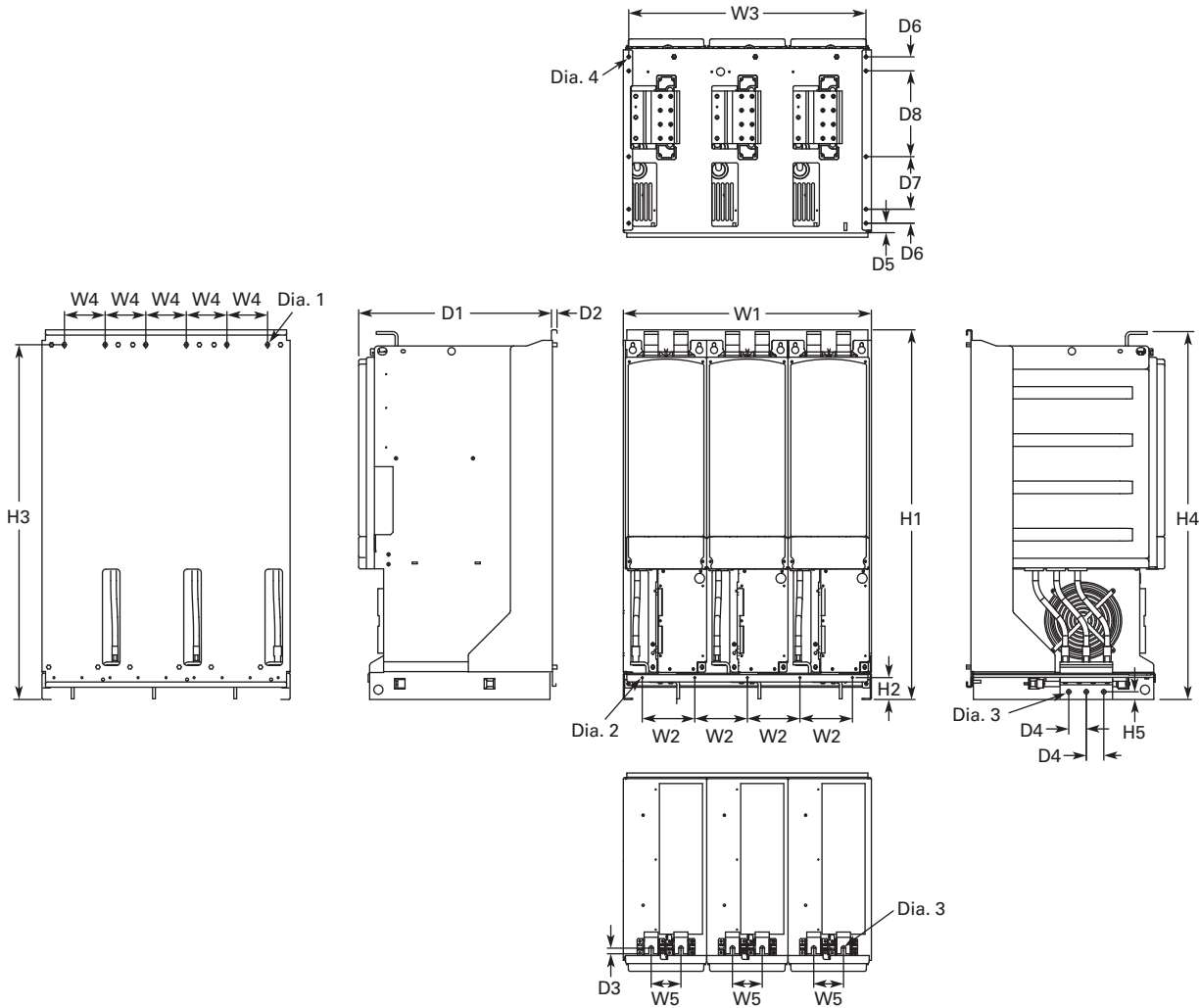

W1	W2	W3	W4	W5	H1	H2	H3	H4	H5	D1	D2	D3	D4	D5	D6	D7	D8	Dia. 1	Dia. 2	Dia. 3	Dia. 4	Weight Lbs (kg)
27.87 (708)	5.91 (150)	26.65 (677)	4.57 (116)	3.35 (85)	41.54 (1055)	2.46 (62.5)	39.86 (1012.5)	41.34 (1050)	0.79 (20)	21.77 (553)	0.51 (13)	0.63 (16)	1.97 (50)	1.06 (27)	1.57 (40)	5.91 (150)	9.64 (244.8)	0.35x0.59 (9x15)	0.18 (4.6)	0.51 (13)	0.37 (9.5)	683 (310)

Notes

9000X FR14 is built of two FR13 modules. Please refer to SPX installation manual for mounting instructions.

FR13 is built from an inverter module and a converter module. Please refer to SPX installation manual for mounting instructions.

Approximate Dimensions in Inches (mm)

FR13, Open Chassis Converter

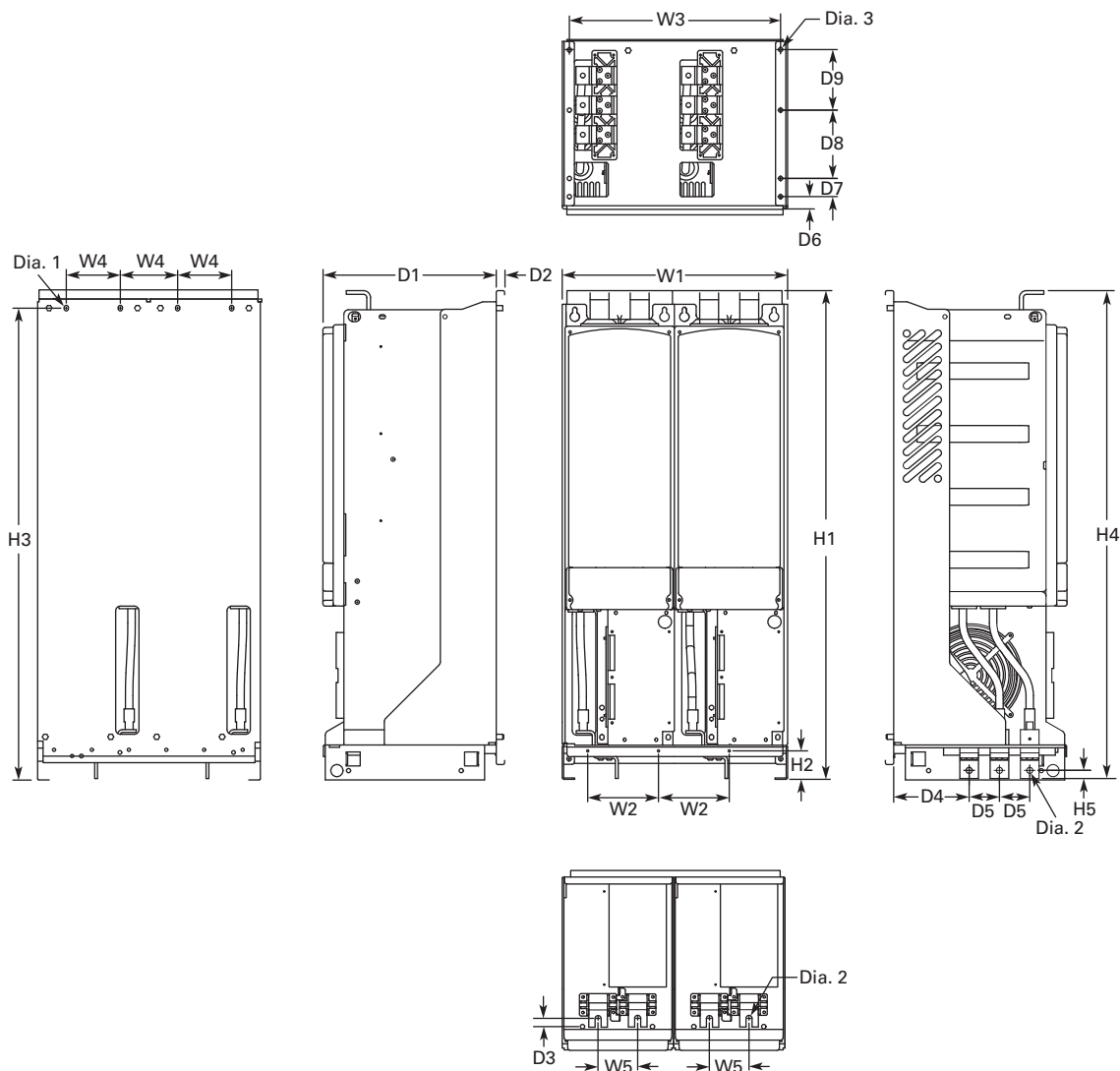

W1	W2	W3	W4	W5	H1	H2	H3	H4	H5	D1	D2	D3	D4	D5	D6	D7	D8	D9	Dia. 1	Dia. 2	Dia. 3	Weight Lbs (kg)
18.74 (476)	5.91 (150)	17.52 (445)	4.57 (116)	3.35 (85)	41.54 (1055)	2.46 (62.5)	39.86 (1012.5)	41.34 (1050)	0.69 (17.5)	14.69 (373)	0.51 (13)	0.73 (18.5)	6.42 (163)	2.56 (65)	1.06 (27)	1.57 (40)	5.91 (150)	5.24 (133)	0.35x0.59 (9x15)	0.51 (13)	0.37 (9.5)	295 (134)

Number of Input Units

480 V			690 V		
Catalog Number	hp	Input Modules	Catalog Number	hp	Input Modules
SPX800 A0-4 A2N1	800	2	SPX800 A0-5 A2N1	800	2
			SPX900 A0-5 A2N1	900	2
			SPXH10 A0-5 A2N1	1000	2

2.10 Adjustable Frequency Drives

SPX Drives

Approximate Dimensions in Inches (mm)

FR13, Open Chassis Converter—900/1000 hp 480 V

2

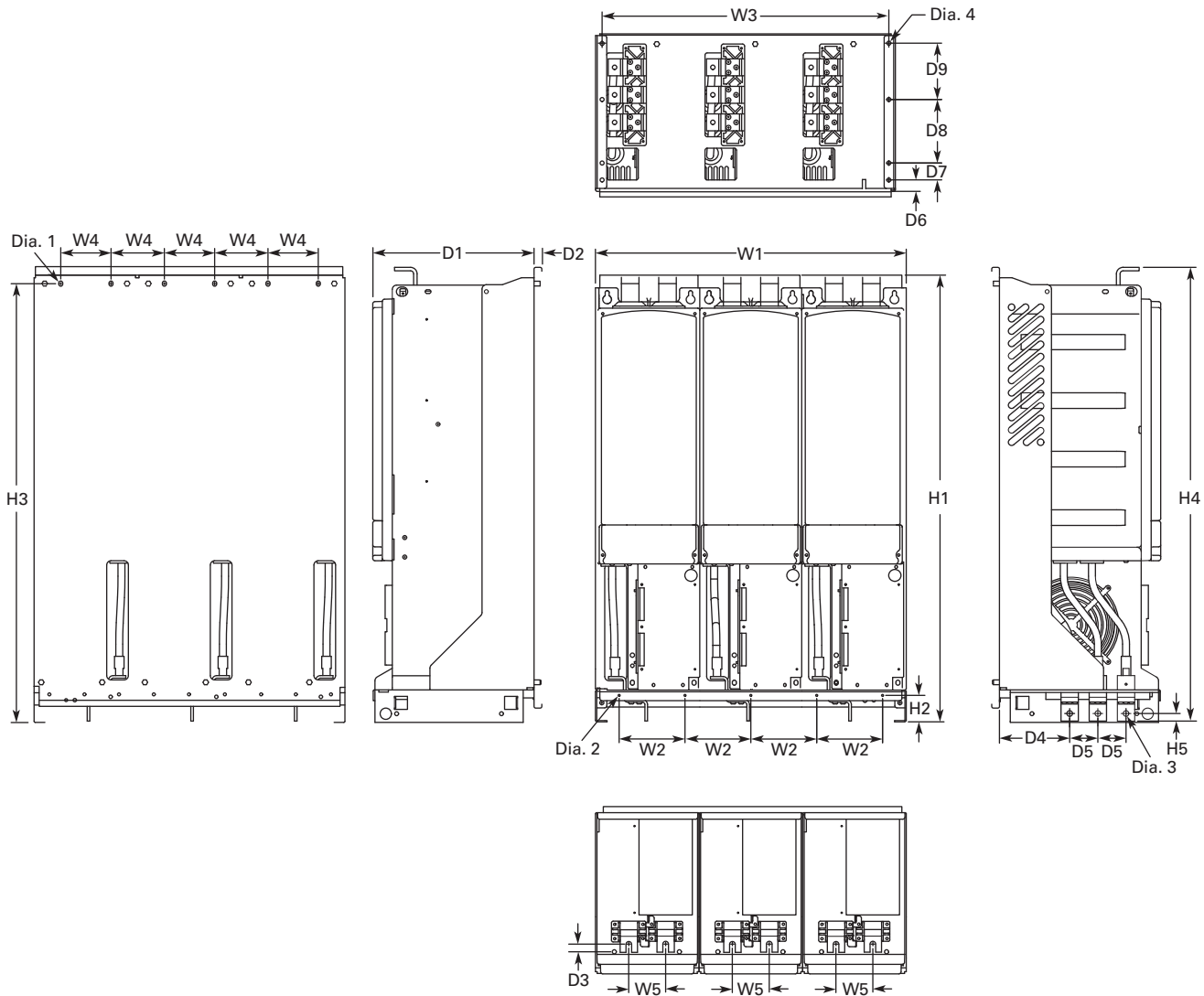

W1	W2	W3	W4	W5	H1	H2	H3	H4	H5	D1	D2	D3	D4	D5	D6	D7	D8	D9	Dia. 1	Dia. 2	Dia. 3	Dia. 4	Weight Lbs (kg)
27.87 (708)	5.91 (150)	26.65 (677)	4.57 (116)	3.35 (85)	41.54 (1055)	2.46 (62.5)	39.86 (1012.5)	41.34 (1050)	0.69 (17.5)	14.69 (373)	0.51 (13)	0.73 (18.5)	6.42 (163)	2.56 (65)	1.06 (27)	1.57 (40)	5.91 (150)	5.24 (133)	0.35x0.59 (9x15)	0.18 (4.6)	0.51 (13)	0.37 (9.5)	443 (201)

Number of Input Units

480 V Catalog Number	hp	Input Modules
SPX900 A0-4 A2N1	900	3
SPXH10 A0-4 A2N1	1000	3

Approximate Dimensions in Inches (mm)

AC Choke Dimensions

Choke Types

Catalog Number	Frame Size	Choke Type ①	Catalog Number	Frame Size	Choke Type ①
Voltage Range 380–500 V			Voltage Range 525–690 V		
SPX 250 4	FR10	CHK0400	SPX 200 5	FR10	CHK0261
SPX 300 4		CHK0520	SPX 250 5		CHK0400
SPX 350 4		CHK0520	SPX 300 5		CHK0400
SPX 400 4	FR11	2 x CHK0400	SPX 400 5	FR11	CHK0520
SPX 500 4		2 x CHK0400	SPX 450 5		CHK0520
SPX 550 4		2 x CHK0400	SPX 500 5		2 x CHK0400
SPX 600 4	FR12	2 x CHK0520	SPX 550 5	FR12	2 x CHK0400
SPX 650 4		2 x CHK0520	SPX 600 5		2 x CHK0400
SPX 700 4		2 x CHK0520	SPX 700 5		2 x CHK0400
SPX 800 4	FR13	2 x CHK0400	SPX 800 5	FR13	2 x CHK0400
SPX 900 4		3 x CHK0520	SPX 900 5		2 x CHK0400
SPX H10 4		3 x CHK0520	SPX H10 5		2 x CHK0400
SPX H12 4	FR14	4 x CHK0520	SPX H13 5	FR14	4 x CHK0400
SPX H16 4		6 x CHK0400	SPX H15 5		6 x CHK0400

CHK0520

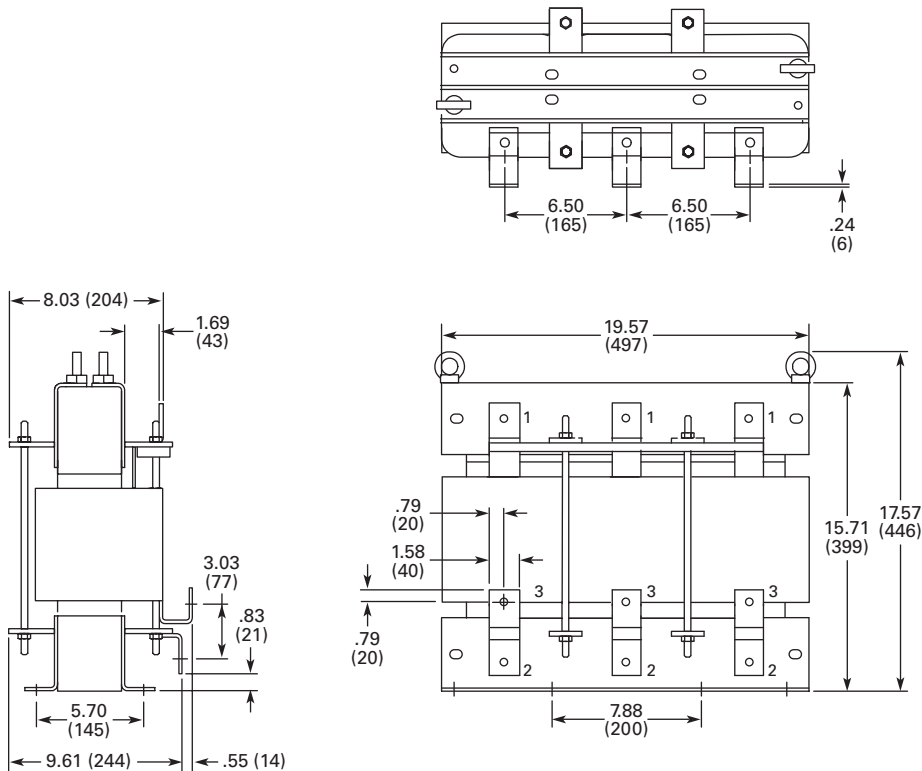

Note

① Chokes are provided with all FR10–FR14 drives.

2.10

Adjustable Frequency Drives

SPX Drives

Approximate Dimensions in Inches (mm)

CHK0400

2

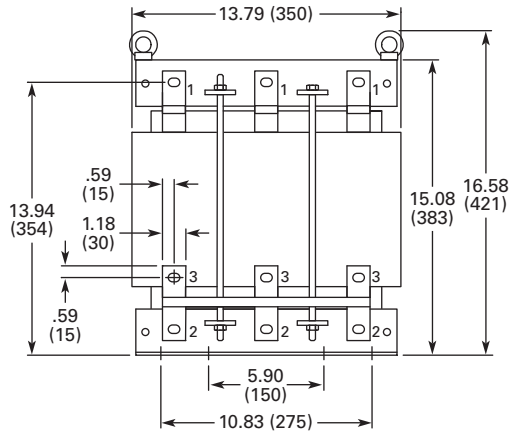
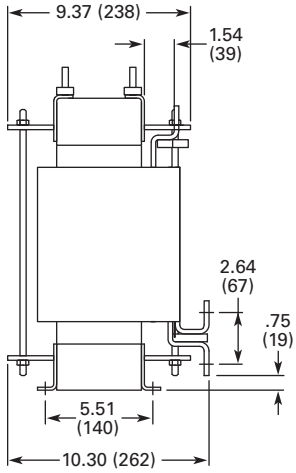
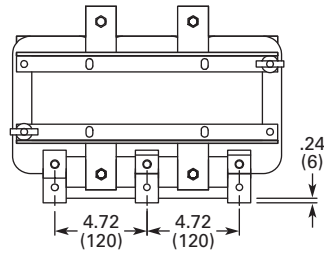

CHK0261

